

- Kontrollera innehållet i förpackningen innan du påbörjar monteringen.
- Förstör inte förpackningen, eftersom den kan användas till att skydda delarna från stötar och repor under monteringen.
- Montera därefter möbelen i den ordning som anges med numreringen.
- Om problem uppstår, kontakta vår kundtjänst.
- Det kan hända att det under upppackning eller monterning frigörs mer eller mindre tydliga dofter av ytbehandlingsmedel från produkten. För att du inte skabesväras av dessa dofter råder vi dig att ställa produkten i ett välventilerat rum, öppna dörrarna helt och placera lådorna vid sidan av möbelen, till dess att dofterna försvunnit.

- Vor Montage den Inhalt Ihres Päckchens kontrollieren
- Die Verpackung nicht zerstören, sie wird Ihnen nützlich sein, um die Teile bei der Montage vor Stößen und Kratzern zu schützen
- Das Möbel dann in der Reihenfolge der Nummerierung zusammenbauen
- Im Problemfall Ihren Kundendienst anrufen
- Lüften Sie Ihre Möbel nach dem Aufbau bitte mit geöffneten Möbeltüren und-schubladen in einem gut durchlüfteten Raum.

- Controlar el contenido de su embalaje antes de proceder al montaje
- No deteriorar el paquete, que le será muy útil para proteger los elementos de golpes y rozaduras durante el montaje.
- Acoplar de seguida el mueble, siguiendo la orden definida por la numeración
- Si tiene problemas, contactar nuestro servicio postventa
- Desde la recepción, ventilar los muebles, con las puertas y cajones abiertos, en una estancia bien ventilada. Renovar regularmente el aire de las estancias

- Verificare il contenuto della confezione prima del montaggio.
- Non eliminare l'imballo che potrà essere utilizzato per proteggere il prodotto dai danni durante il montaggio.
- Montare l'articolo seguendo l'ordine di numerazione.
- In caso di necessità contattare il nostro servizio post-vendita.
- Al ricevimento, areare i vostri mobili, aprendo porte e cassetti, in una stanza ben ventilata. Ricambiare l'aria della stanza regolarmente

- Tarkista pakkauksen osat ennen kokoamisen aloittamista.
- Älä hajota pakkausta. Se on hyödyllinen kokoamisen yhteydessä osien suojaamiseksi naarmuilta.
- Kokoa huonekalu seuraamalla ohjelta numerojärjestyksessä.
- Ongelman tapauksessa, ottakaa yhteys jälki-myyntipalveluumme.
- On mahdollista, että tuote avaamisen ja kokoamisen yhteydessä vapauttaa lakaa hajua johtuen sen säilytyksestä pakkauksen sisässä. Jotta tämä haju ei häiritseisi teitä, suosittelemme asettamaan tuotteen kunnolla ilmastoitua tilaan, avaamaan sen ovet ja irrottamaan laatikon, kunnes haju on kadonnut.

- De inhoud van uw pakket controleren alvorens met de montage te beginnen
- De Verpakking niet beschadigen, deze kan heel handig zijn om de onderdelen te beschermen tegen schokken en krassen tijdens de montage.
- Zet vervolgens het meubel in elkaar in de volgorde die is bepaald in de nummering
- Neem bij problemen contact op met onze klantenservice.
- Laat na ontvangst uw meubels luchten (deuren en laden open) in een goed geventileerde ruimte. Zorg regelmatig voor frisse lucht in uw kamer

- Contrôler le contenu de votre colis avant de procéder au montage.
- Ne détériorez pas l'emballage, il vous sera très utile pour protéger les éléments des coups et rayures pendant le montage.
- Assemblez ensuite le meuble en suivant l'ordre défini par la numérotation.
- En cas de problème contactez notre service après-vente.
- A réception, aérer vos meubles, portes et tiroirs ouverts, dans une pièce bien ventilée. Renouveler régulièrement l'air de vos pièces.

- Check the content of your parcel before assembling.
- Do not throw away the packing which could be very useful to protect the panels from knocks and scratches when assembling.
- Assemble the article following the order of the numbers indicated.
- Should any problems arise, please contact our After Sale Service.
- Upon receipt, place the furniture in a well-ventilated room and leave doors and drawers open to allow the air to circulate. Change the air in your rooms on a regular basis.

- Confira o conteúdo da sua encomenda antes de iniciar a montagem.
- Não danifique a embalagem, poderá ser-lhe útil para proteger os elementos de golpes ou riscos durante a montagem.
- Proceda à montagem do móvel seguindo a ordem definida pela numeração.
- Para qualquer esclarecimento, contacte os nossos serviços através do telefone.
- Quando da sua recepção, arejar os seus móveis, portas e gavetas abertas, numa divisão bem ventilada. Renovar regularmente o ar das suas divisões.

Notice de montage / Assembly instructions / Instruções de montagem / Prospecto de montaje / Montageanleitung / Istruzioni di montaggio / Montagehandleiding / Asennusohjeet / Monteringsanvisningar

F Informations à conserver

Attention: tenir les vis et petits éléments et sachets hors de portée des enfants

Attention! Bien identifier les éléments avant de commencer le montage

A monter par un Adulte

Ne pas utiliser votre article lorsque l'un de ses éléments est cassé ou manquant

En cas de problème contactez notre service après vente

Un adulte doit vérifier le bon assemblage avant l'emploi

GB Keep this information for future reference

Caution : Keep all screws, small parts and plastic bag out of the reach of small children

Caution : Check all parts before assembling

To be assembled by an adult

Never use your item if any of its parts are broken or missing

Should any problems arise, please contact our After Sales Service

Assembly must be checked by an adult before use

P Informação a conservar

Precaução : Mantenha peças os parafusos, acessórios pequenos e saco de plástico fora do alcance das crianças

Atenção ! Identifique os parafusos antes de começar a montagem

A ser montado por um adulto

Não utilizar o artigo se um dos elementos está em falta ou danificado

Para qualquer esclarecimento, contacte os nossos serviços através do telefone

Um adulto deve verificar a boa montagem antes da utilização

S Guardar esta información para futuras referencias

Atención: mantener los tornillos, los pequeños elementos y bolsitas fuera del alcance de los niños

Atención! Identificar los elementos antes de empezar el montaje

A montar por un adulto

No utilizar este artículo si uno de los elementos falta o esta roto

Si tiene problemas, contactar nuestro servicio postventa.

Un adulto debe comprobar el buen montaje antes de la utilización

G Aufzubewahrende Informationen

Achtung: die Schrauben und kleinen Teile ausserhalb der Reichweite von Kindern lagern

Achtung: Vor Montagebeginn alle Teile identifizieren

Von einem Erwachsenen zu montieren

Ihren Artikel nicht benutzen, wenn eines seiner Bestandteile beschädigt ist oder fehlt

Im Problemfall Ihren Kundendienst anrufen

Die korrekte Montage muss vor Gebrauch von einem Erwachsenen geprüft werden

I Conservare le istruzioni per futuro utilizzo

Attenzione! Tenere le viti ed i componenti di piccole dimensioni lontano dalla portata dei bambini

Attenzione! Controllare i pezzi prima del montaggio

Il montaggio deve essere eseguito da un adulto

L'articolo non deve essere utilizzato in caso di elementi mancanti o danneggiati

In caso di necessità contattare il nostro servizio post-vendita

Un adulto dovrà verificare il corretto montaggio prima dell'uso

D Informatie om te bewaren

Waarschuwing: schroeven en kleine elementen en zakjes buiten bereik van kinderen houden

Let op! De elementen goed identificeren alvorens met de montage te beginnen

Moet door een volwassene worden gemonteerd

Uw artikel niet gebruiken wanneer een van de onderdelen kapot is of ontbreekt

Neem bij problemen contact op met onze klantenservice

Voor gebruik moet een volwassene controleren dat het product goed in elkaar is gezet

FI Säilytettävät tiedot

Varoitus: pidä ruuvit, pienet osat ja pussit poissa lasten ulottuvilta

Tarkista pakkauksen osat ennen kokoamisen aloittamista

Aikuisen koottava.

Älä käytä tuotetta, jos jokin sen osista puuttuu tai on rikkoutunut

Ongelman tapauksessa, ottakaa yhteys jälkimyyntipalveluumme

Aikuisen tulee varmistaa kunnollinen kokoaminen ennen käyttöä

SE Ta vara på dessa anvisningar

Obs : Förvara skruvarna, smådelarna och påsarna utom räckhåll för barn

Kontrollera innehållet i förpackningen innan du påbörjar monteringen

Ska monteras av en vuxen.

Använd aldrig denna produkt om någon del saknas eller är trasig

Om problem uppstår, kontakta vår kundtjänst

Monteringen ska ses över av en vuxen innan användning

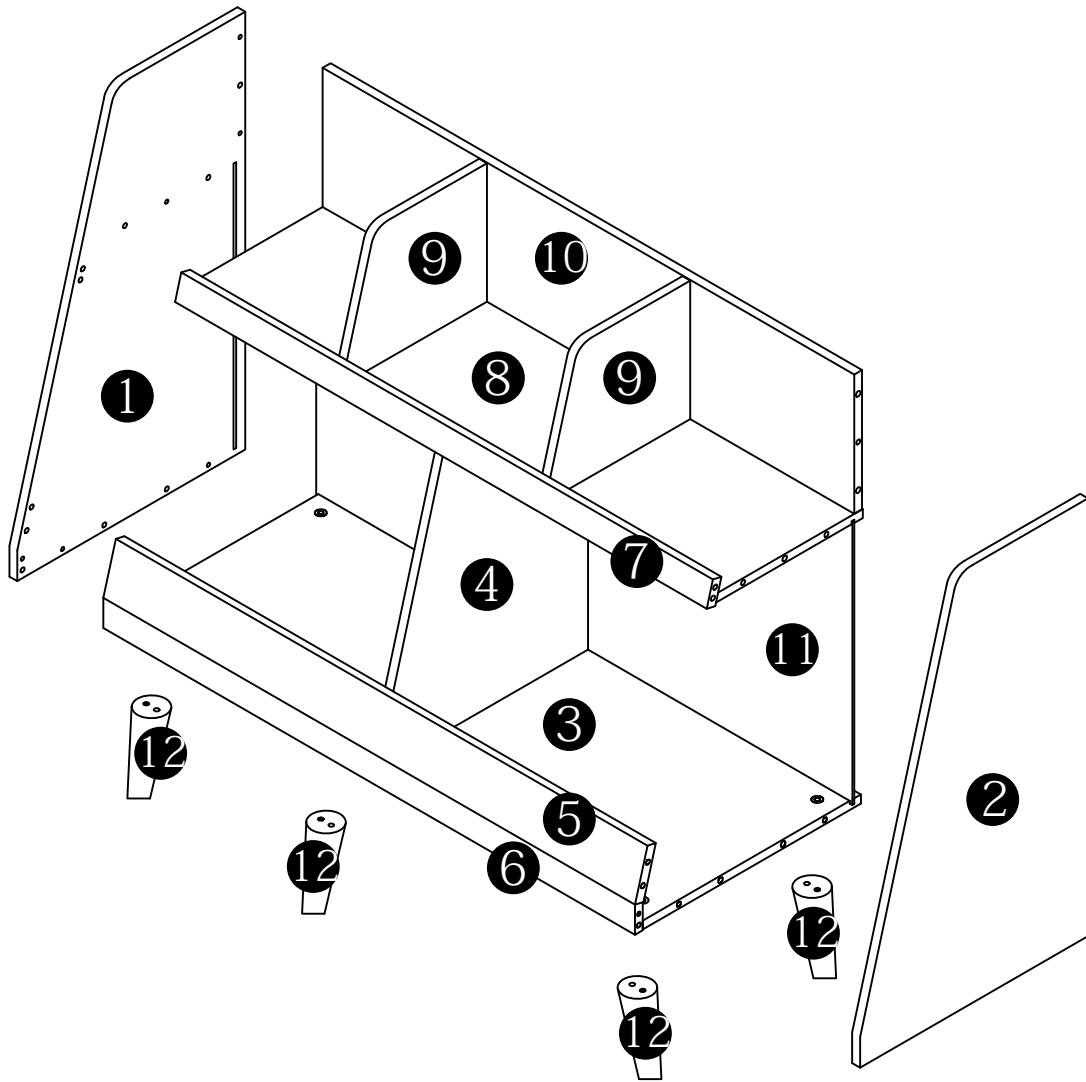

Ax15

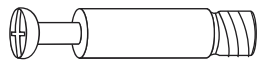

Bx16

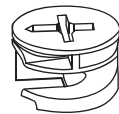

Cx26

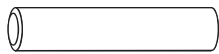

Dx13

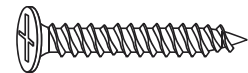

Ex4



Fx1

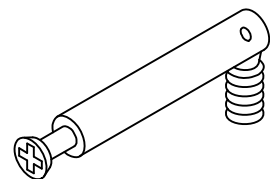

Gx2



1

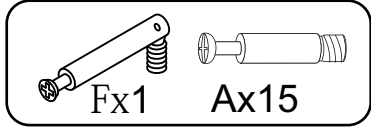
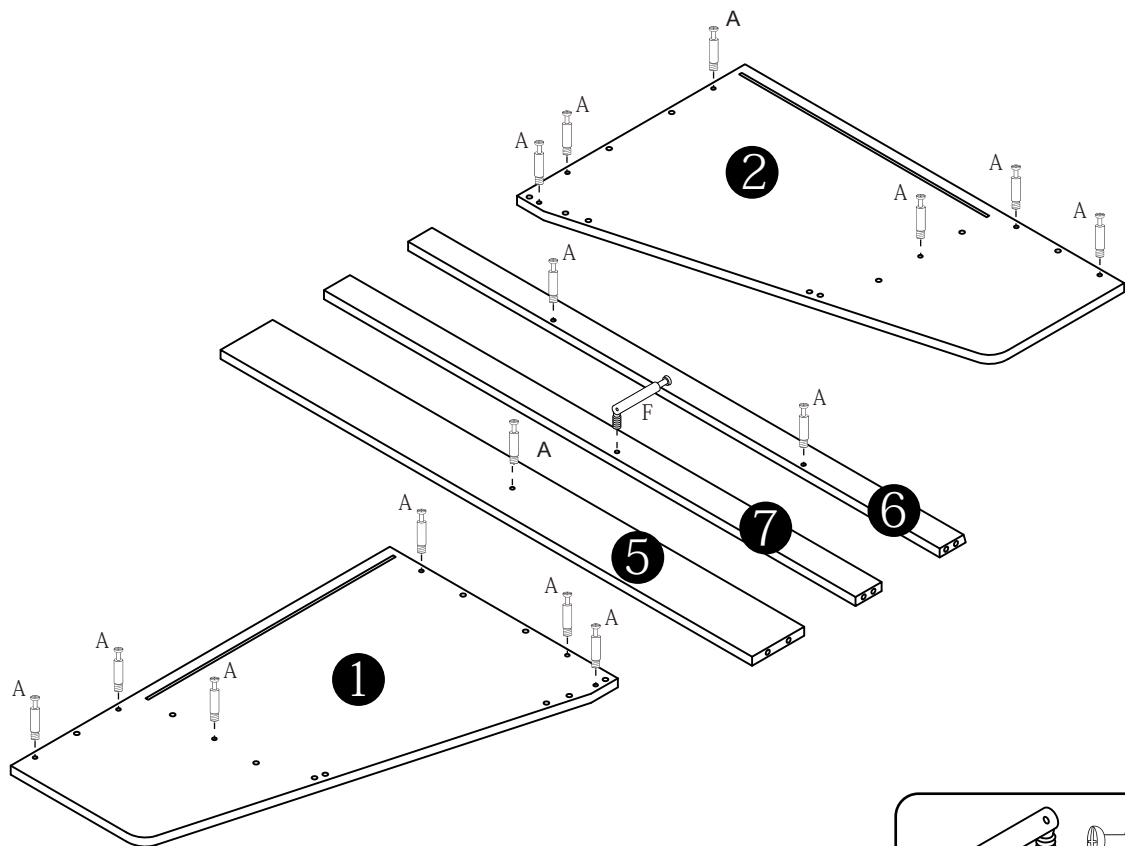

2

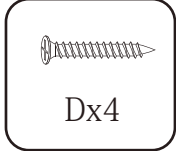
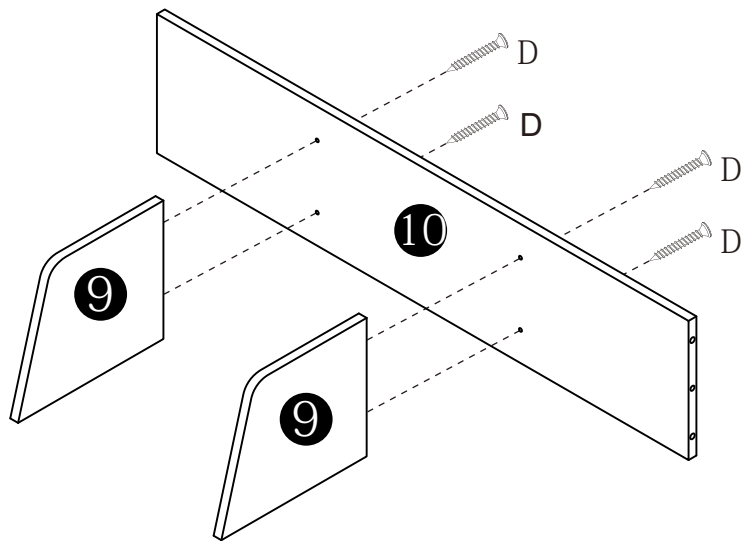

3

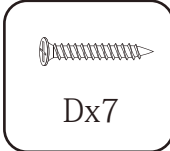
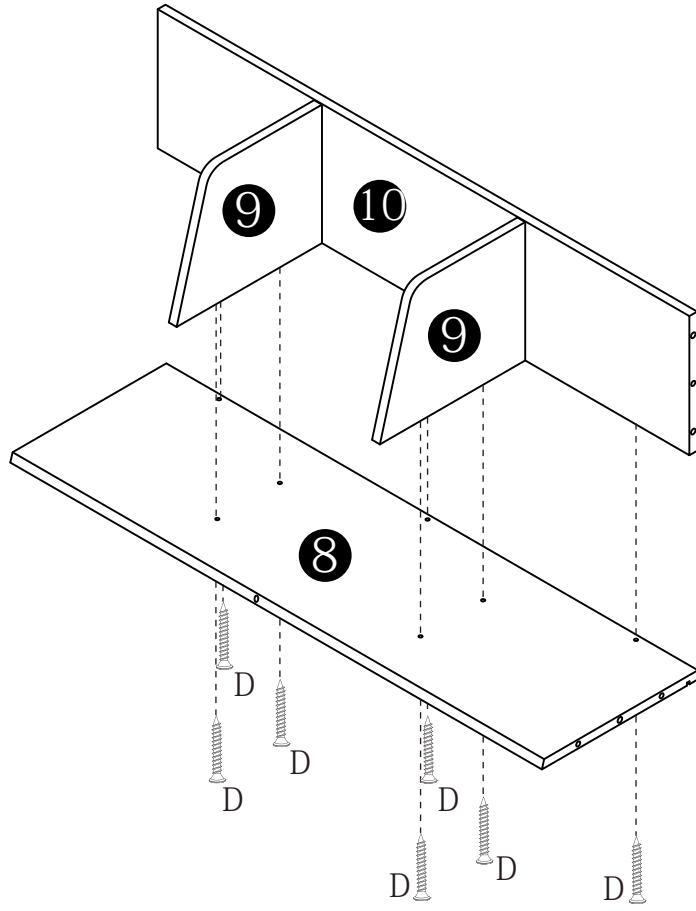

4

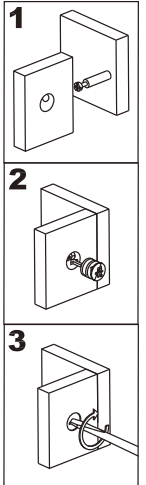
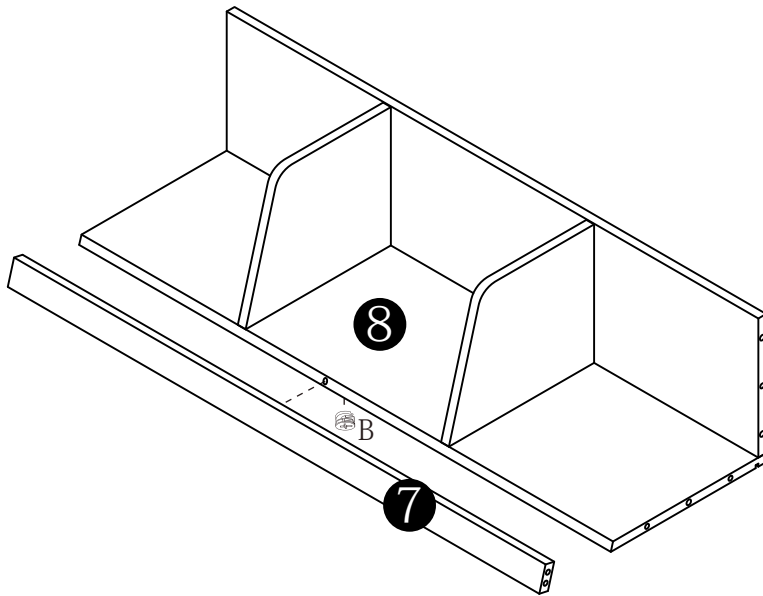

5

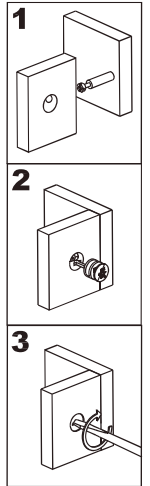
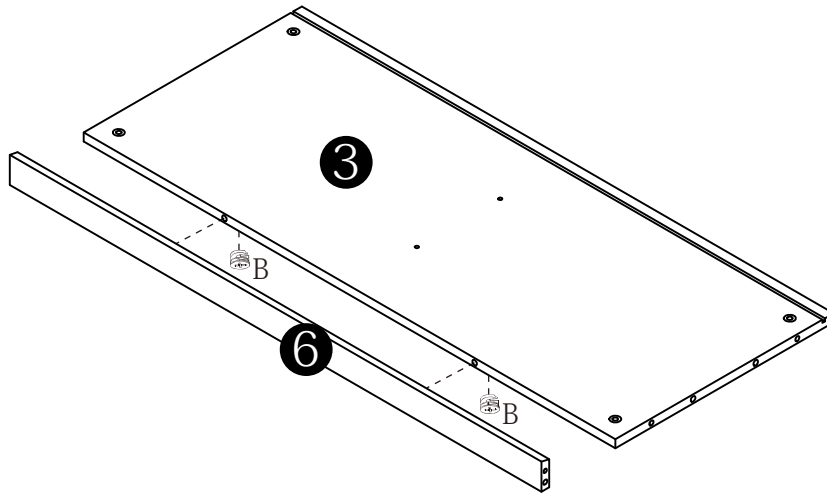

6

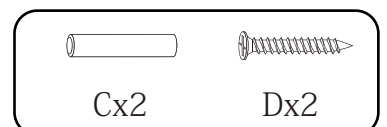
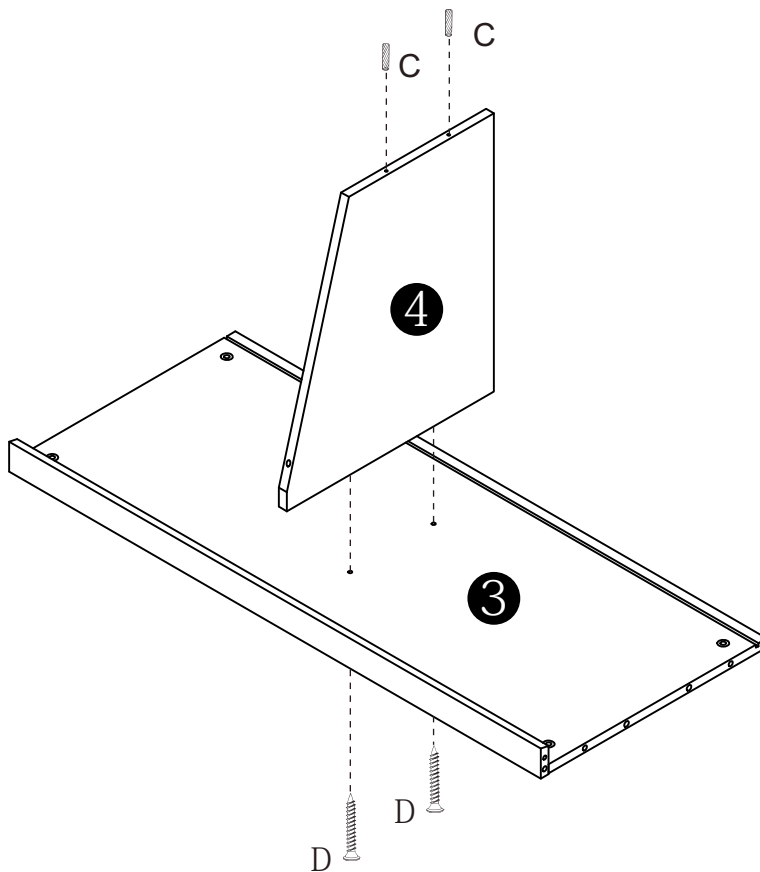

7

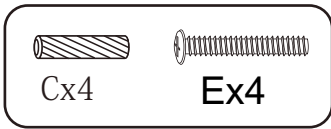
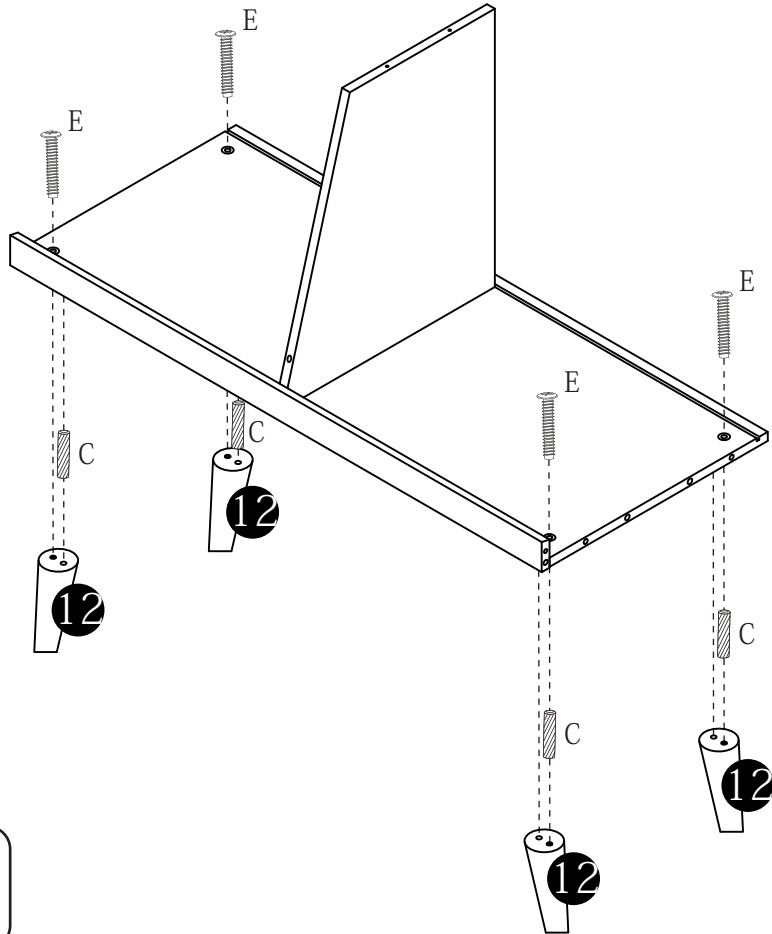

8

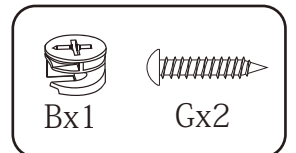
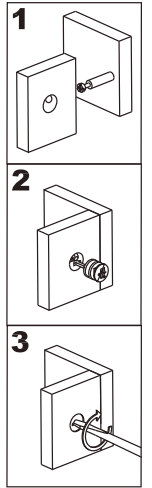
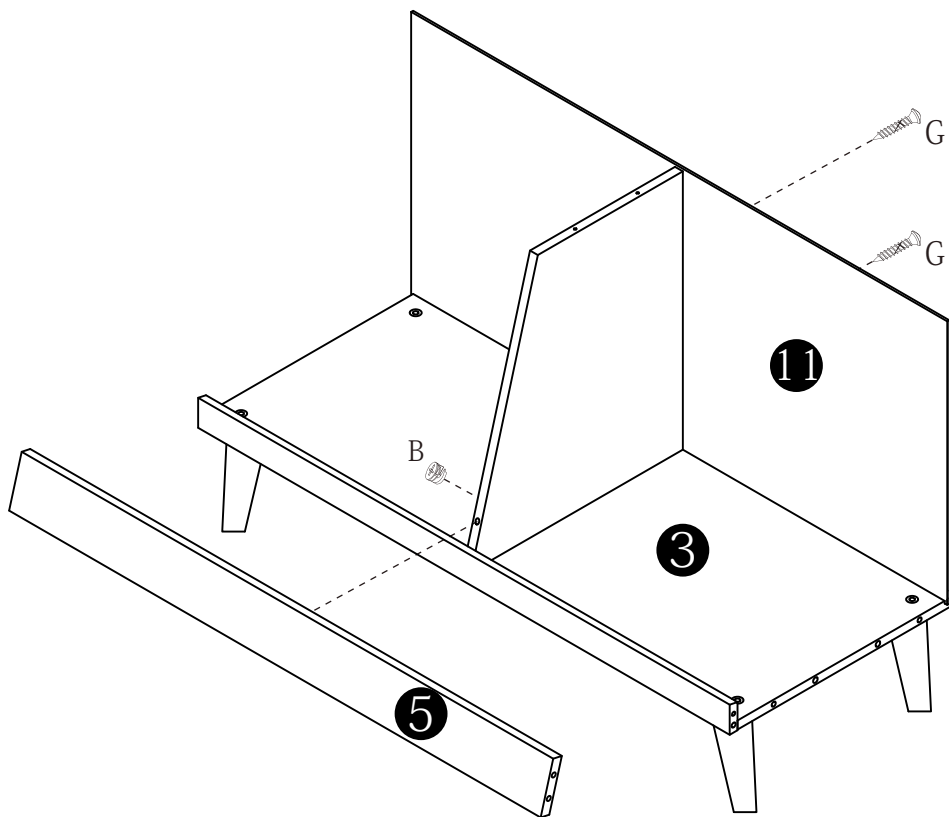

9

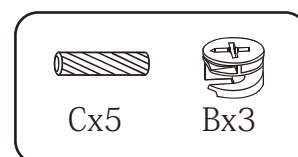
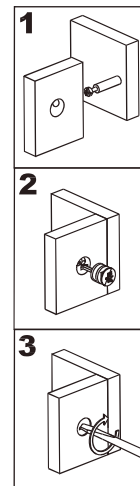
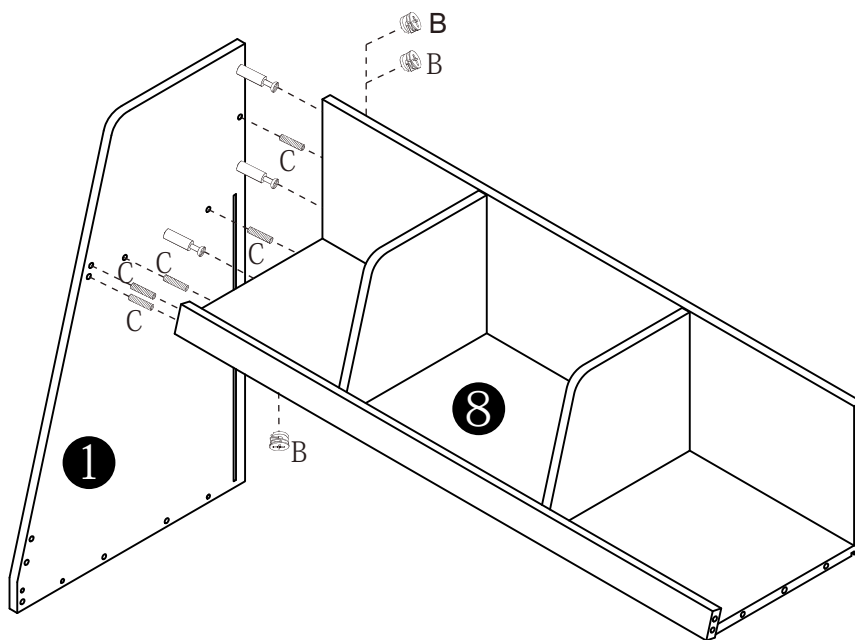

10

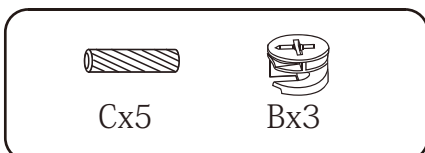
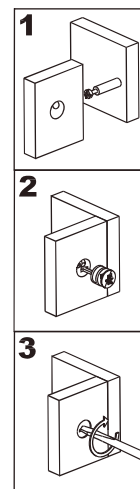
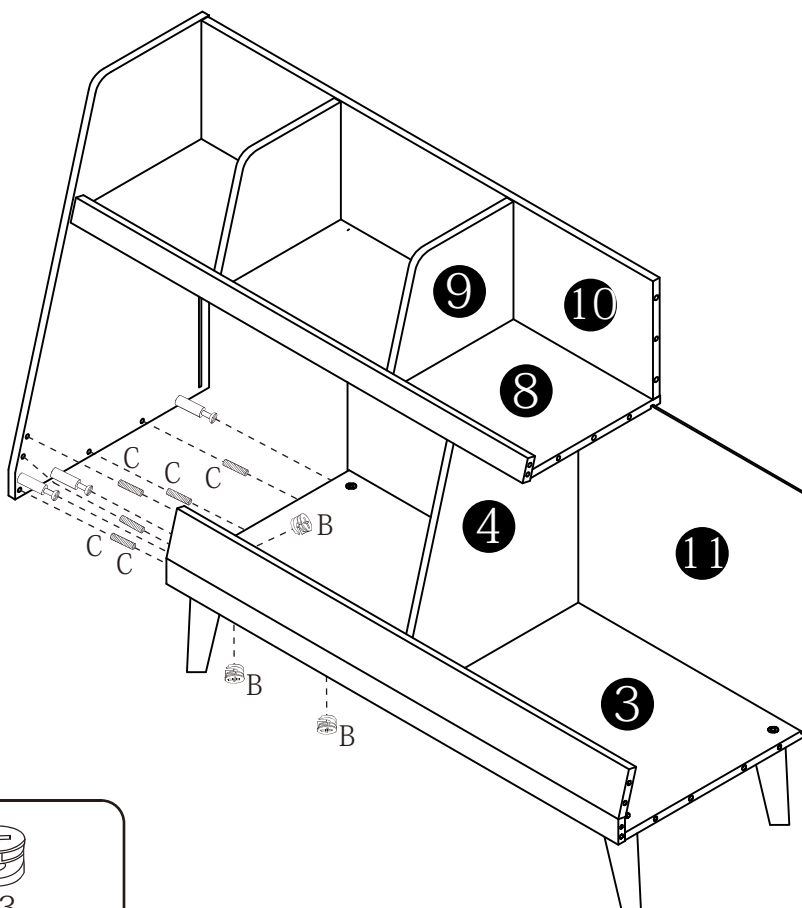

10

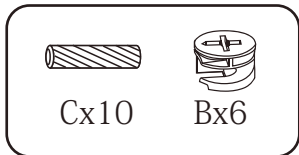
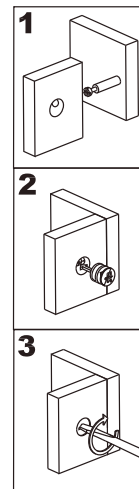
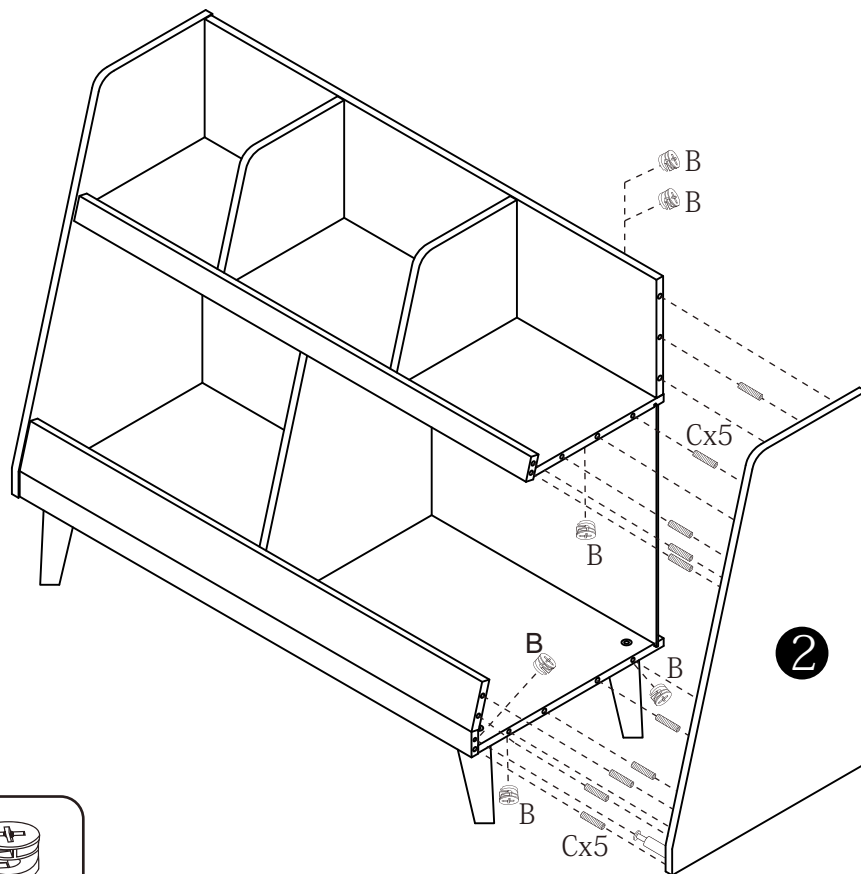

11

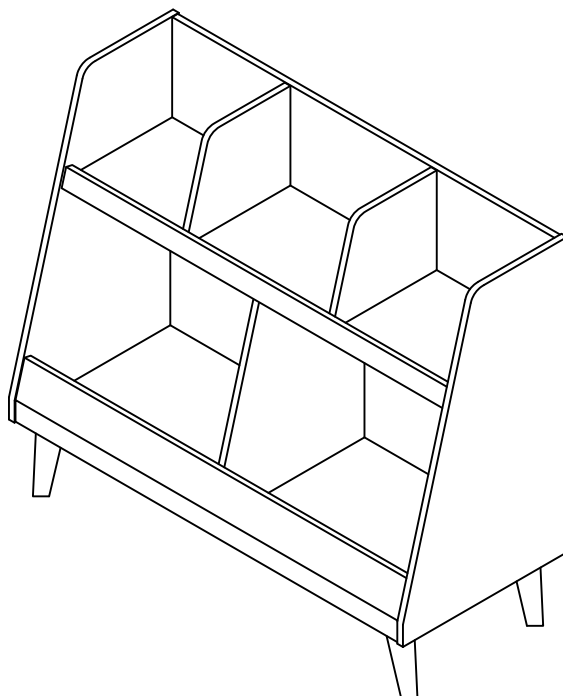

Importé par / Imported by / Importado por / Importado por / Importiert von / Importato da /
Geïmporteerd door / maahantuojaja / Importeras av

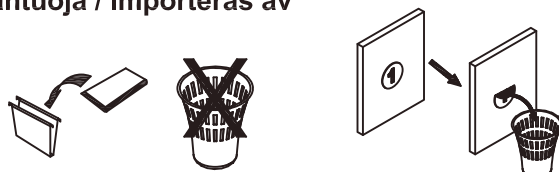

SADAS - VERTBAUDET
216, Rue Winoc Chocqueel
59200 Tourcoing - FRANCE