

- Vor Montage den Inhalt Ihres Päckchens kontrollieren
- Die Verpackung nicht zerstören, sie wird Ihnen nützlich sein, um die Teile bei der Montage vor Stößen und Kratzern zu schützen
- Das Möbel dann in der Reihenfolge der Nummerierung zusammenbauen
- Im Problemfall Ihren Kundendienst anrufen
- Lüften Sie Ihre Möbel nach dem Aufbau bitte mit geöffneten Möbeltüren und-schubladen in einem gut durchlüfteten Raum.



- Controlar el contenido de su embalaje antes de proceder al montaje
- No deteriorar el paquete, que le será muy útil para proteger los elementos de golpes y rozaduras durante el montaje.
- Acoplar de seguida el mueble, siguiendo la orden definida por la numeración
- Si tiene problemas, contactar nuestro servicio postventa
- Desde la recepción, ventilar los muebles, con las puertas y cajones abiertos, en una estancia bien ventilada. Renovar regularmente el aire de las estancias



- Verificare il contenuto della confezione prima del montaggio.
- Non eliminare l'imballo che potrà essere utilizzato per proteggere il prodotto dai danni durante il montaggio.
- Montare l'articolo seguendo l'ordine di numerazione.
- In caso di necessità contattare il nostro servizio post-vendita.
- Al ricevimento, areare i vostri mobili, aprendo porte e cassetti, in una stanza ben ventilata. Ricambiare l'aria della stanza regolarmente



- De Inhoud van uw pakket controleren alvorens met de montage te beginnen
- De Verpakking niet beschadigen, deze kan heel handig zijn om de onderdelen te beschermen tegen schokken en krassen tijdens de montage.
- Zet vervolgens het meubel in elkaar in de volgorde die is bepaald in de nummering
- Neem bij problemen contact op met onze klantenservice.
- Laat na ontvangst uw meubels luchten (deuren en laden open) in een goed geventileerde ruimte. Zorg regelmatig voor frisse lucht in uw kamer



- Contrôler le contenu de votre colis avant de procéder au montage.
- Ne détériorez pas l'emballage, il vous sera très utile pour protéger les éléments des coups et rayures pendant le montage.
- Assemblez ensuite le meuble en suivant l'ordre défini par la numérotation.
- En cas de problème contactez notre service après vente.
- A réception, aérer vos meubles, portes et tiroirs ouverts, dans une pièce bien ventilée. Renouvelez régulièrement l'air de vos pièces.



- Check the content of your parcel before assembling.
- Do not throw away the packing which could be very useful to protect the panels from knocks and scratches when assembling.
- Assemble the article following the order of the numbers indicated.
- Should any problems arise, please contact our After Sale Service.
- Upon receipt, place the furniture in a well-ventilated room and leave doors and drawers open to allow the air to circulate. Change the air in your rooms on a regular basis.



- Confira o conteúdo da sua encomenda antes de iniciar a montagem.
- Não danifique a embalagem, poderá ser-lhe útil para proteger os elementos de golpes ou riscos durante a montagem.
- Proceda à montagem do móvel seguindo a ordem definida pela numeração.
- Para qualquer esclarecimento, contacte os nossos serviços através do telefone.
- Aquando da sua recepção, arejar os seus móveis, portas e gavetas abertos, numa divisão bem ventilada. Renovar regularmente o ar das suas divisões.

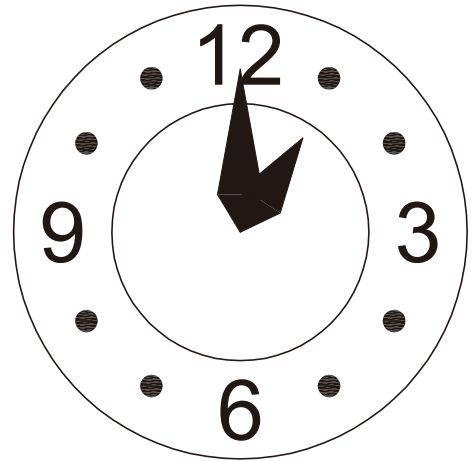
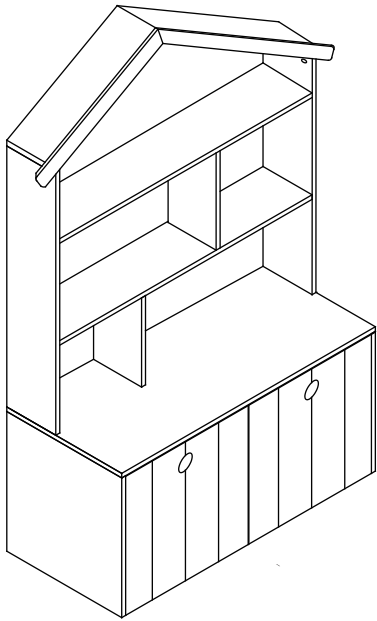

60 Min

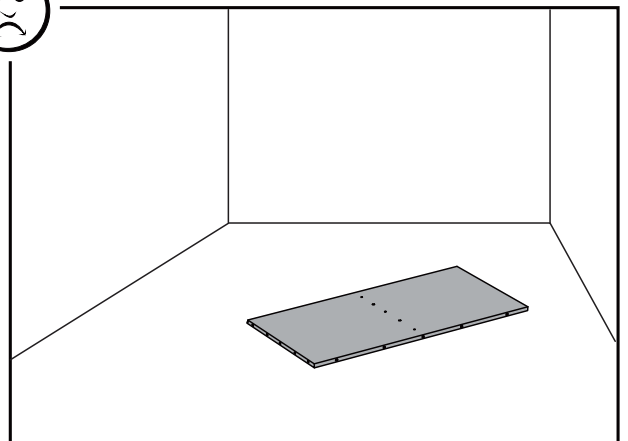
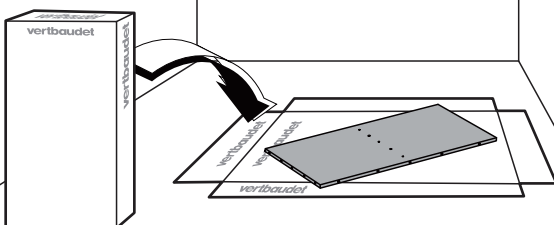
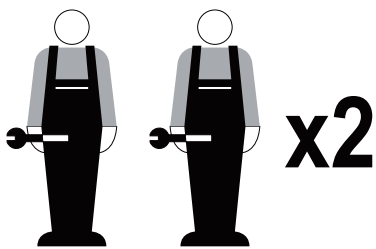
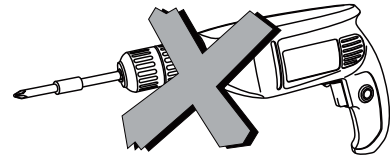
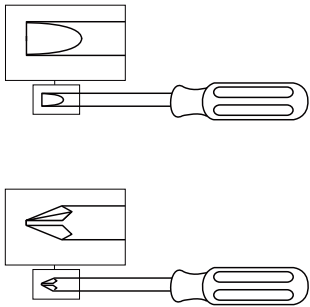

**FR - Notice de montage / EN - Assembly instructions / PT - Instruções de montagem / ES - Prospecto de montaje / DE - Montageanleitung / IT - Istruzioni di montaggio / NL - Montagehandleiding**

**FR – IMPORTANT! CONSERVER POUR CONSULTATION ULTERIEURE: LIRE ATTENTIVEMENT**

- A monter par un adulte. Un adulte doit vérifier le bon assemblage avant l'emploi
- Attention! tenir les vis et petits éléments et sachets hors de portée des enfants
- Bien identifier les éléments avant de commencer le montage
- Ne pas utiliser votre article lorsque l'un de ses éléments est cassé ou manquant
- En cas de problème contactez notre service après-vente
- Toujours suivre les instructions du fabricant
- Entretien: nettoyer avec un chiffon doux et sec. En cas de taches plus grosses, frottez soigneusement avec une éponge légèrement humide et non abrasive
- Ne pas monter sur le produit

**EN – IMPORTANT! KEEP FOR FUTURE REFERENCE: READ CAREFULLY**

- To be assembled by an adult. Assembly must be checked by an adult before use
- Warning ! keep all screws, small parts and plastic bags out of the reach of children
- Properly identify all parts before assembling
- Never use your item if any of its parts are broken or missing
- Should any problems arise, please contact our After Sales Service
- Manufacturer's instructions shall be followed at all times
- Care: clean with a soft, dry cloth. In case of larger stains, carefully rub with a slightly damp, non-abrasive sponge
- Do not climb on this product

**PT – IMPORTANTE! GARDE PARA CONSULTA POSTERIOR: LER ESTAS INSTRUÇÕES CUIDADOSAMENTE**

- A ser montado por um adulto. Um adulto deve verificar a boa montagem antes da utilização
- Atenção! mantenha os parafusos, acessórios pequenos e saco de plástico fora do alcance das crianças
- Identique bem os acessórios antes de começar a montagem
- Não utilizar o artigo se um dos elementos está em falta ou danificado
- Para qualquer esclarecimento, contacte os nossos serviços através do telefone
- As instruções do fabricante devem ser sempre cumpridas
- Manutenção: limpe com um pano macio e seco. Em caso de manchas maiores, esfregue cuidadosamente com uma esponja ligeiramente húmida e não abrasiva
- Não suba para cima do produto

**ES – IMPORTANTE! CONSERVAR PARA FUTURAS CONSULTAS: LEER DETENIDAMENTE**

- A montar por un adulto. Un adulto debe comprobar el buen montaje antes de la utilización
- ¡Advertencia! mantener los tornillos, los pequeños elementos y bolsitas fuera del alcance de los niños
- Identificar debidamente los elementos antes de empezar el montaje
- No utilizar este artículo si uno de los elementos falta o esta roto
- Si tiene problemas, contactar nuestro servicio postventa
- Deben seguirse siempre las instrucciones del fabricante
- Cuidados: limpiar con un paño suave y seco. En caso de manchas grandes, frotar con cuidado utilizando una esponja húmeda no abrasiva

- No subir sobre el producto

### **DE – WICHTIG! FÜR SPÄTERE BEZUGNAHME AUFBEWAHREN: SORGFÄLTIG LESEN**

- Von einem Erwachsenen zu montieren. Die korrekte Montage muss vor Gebrauch von einem Erwachsenen geprüft werden
- Achtung! die Schrauben und kleinen Teile ausserhalb der Reichweite von Kindern lagern
- Vor Montagebeginn alle Teile identifizieren
- Ihren Artikel nicht benutzen, wenn eines seiner Bestandteile beschädigt ist oder fehlt
- Im Problemfall Ihren Kundendienst anrufen
- Stets die Herstelleranweisungen beachten
- Wartung: Mit einem weichen, trockenen Tuch reinigen. Bei größeren Flecken vorsichtig mit einem leicht feuchten, nicht scheuernden Schwamm abreiben
- Nicht auf das Produkt steigen

### **IT - IMPORTANTE! CONSERVARE QUESTE INFORMAZIONI PER ULTERIORI CONSULTAZIONI: LEGGI ATTENTAMENTE**

- Il montaggio deve essere eseguito da un adulto. Un adulto dovrà verificare il corretto montaggio prima dell'uso
- Avvertenza! tenere le viti ed i componenti di piccole dimensioni lontano dalla portata dei bambini
- Controllare i pezzi prima del montaggio
- L'articolo non deve essere utilizzato in caso di elementi mancanti o danneggiati
- In caso di necessità contattare il nostro servizio post-vendita
- Seguire sempre le istruzioni del costruttore
- Manutenzione: pulire con un panno morbido e asciutto. Per le macchine più grandi, strofinare accuratamente con una spugna leggermente umida e non abrasiva
- Non salire sul prodotto

### **NL - BELANGRIJK! BEWAAR VOOR LATERE RAADPLEGING: LEES AANDACHTIG**

- Moet door een volwassene worden gemonteerd. Voor gebruik moet een volwassene controleren dat het product goed in elkaar is gezet
- Opgelet! schroeven en kleine elementen en zakjes buiten bereik van kinderen houden
- De elementen goed identificeren alvorens met de montage te beginnen
- Uw artikel niet gebruiken wanneer een van de onderdelen kapot is of ontbreekt
- Neem bij problemen contact op met onze klantenservice
- Volg altijd de instructies van de fabrikant
- Onderhoud: maak schoon met een zachte en droge doek. In geval van grotere vlekken, veeg voorzichtig schoon met een licht bevochtigde en niet-schurende spons
- Niet op het product klimmen



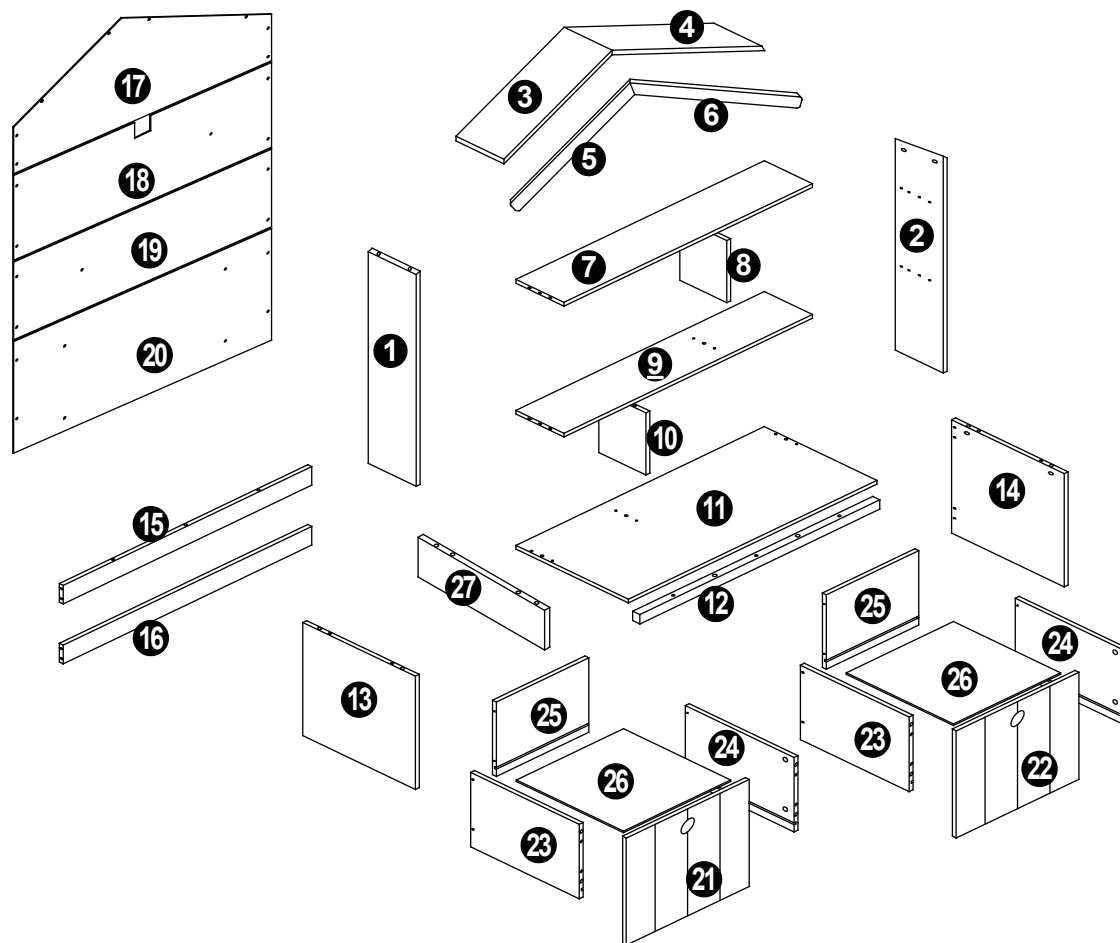

**Ax43**



**Gx32**

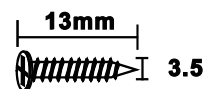

**Bx37**

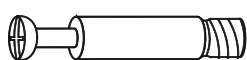

**Hx3**

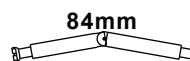

**Cx40**

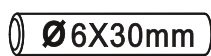

**Ix8**

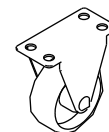

**Dx2**

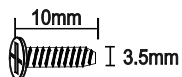

**Jx1**

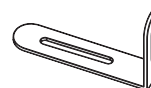

**Ex19**

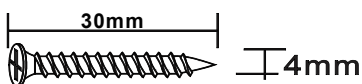

**Fx30**

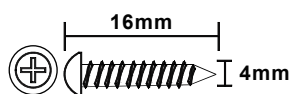

1

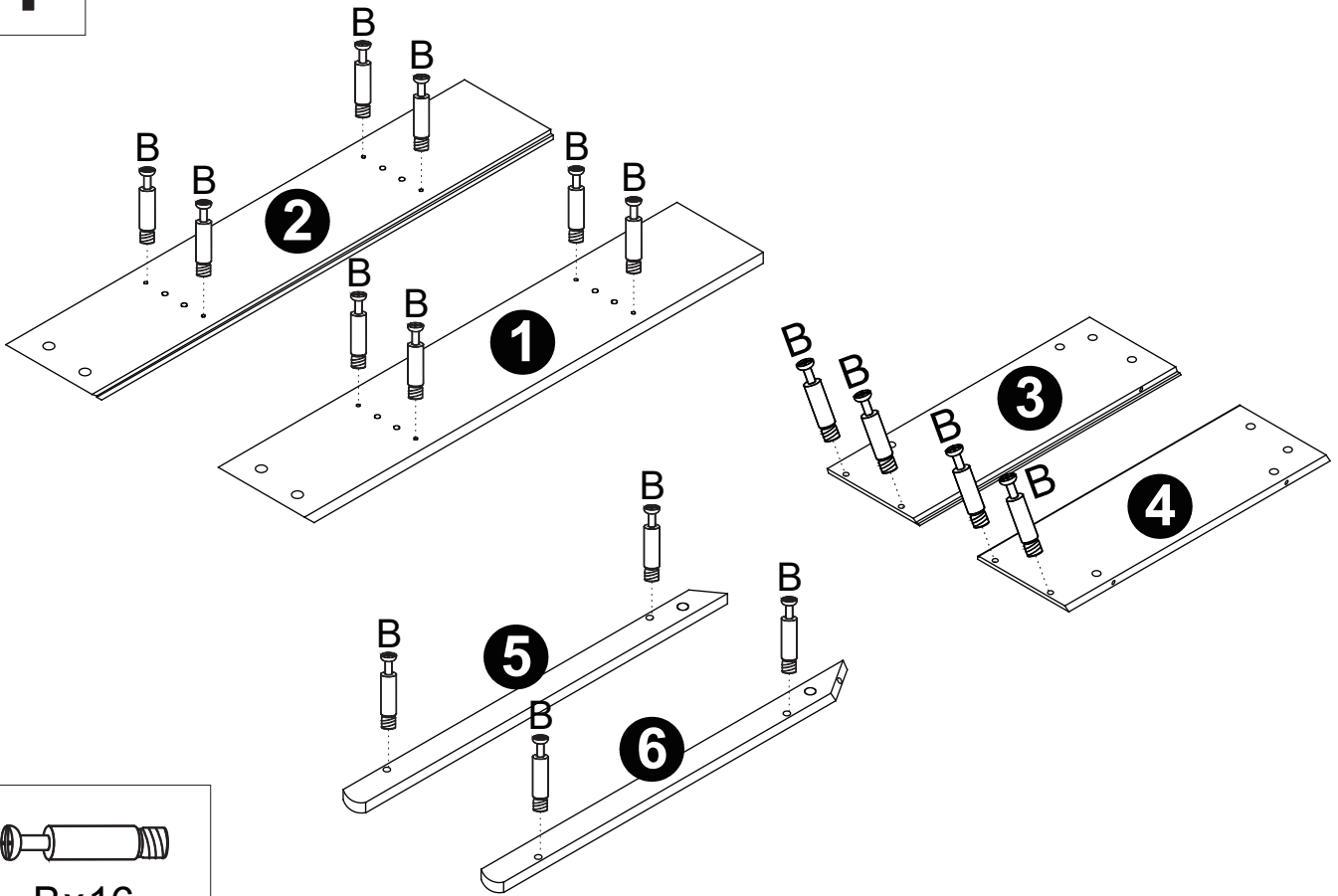

2

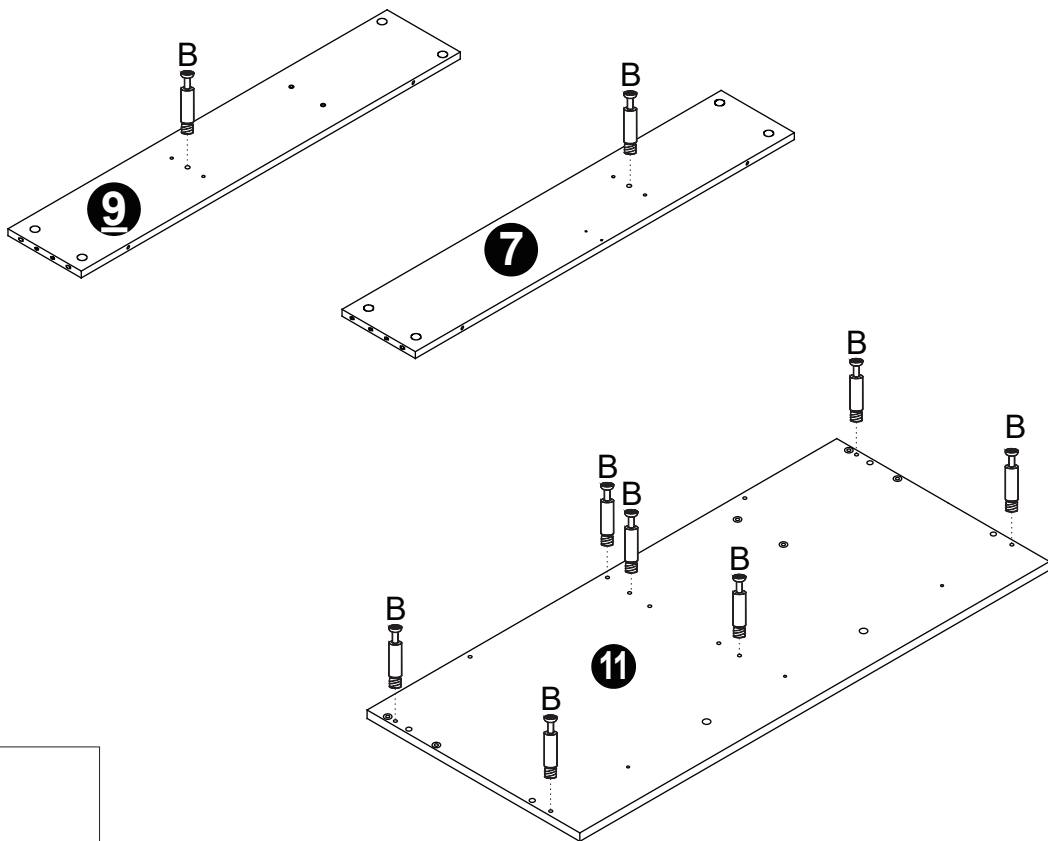

3

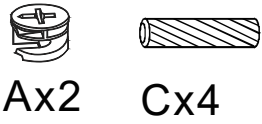
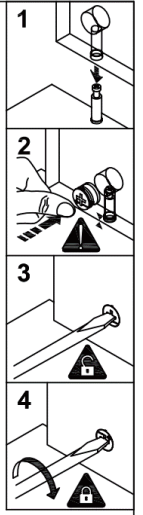
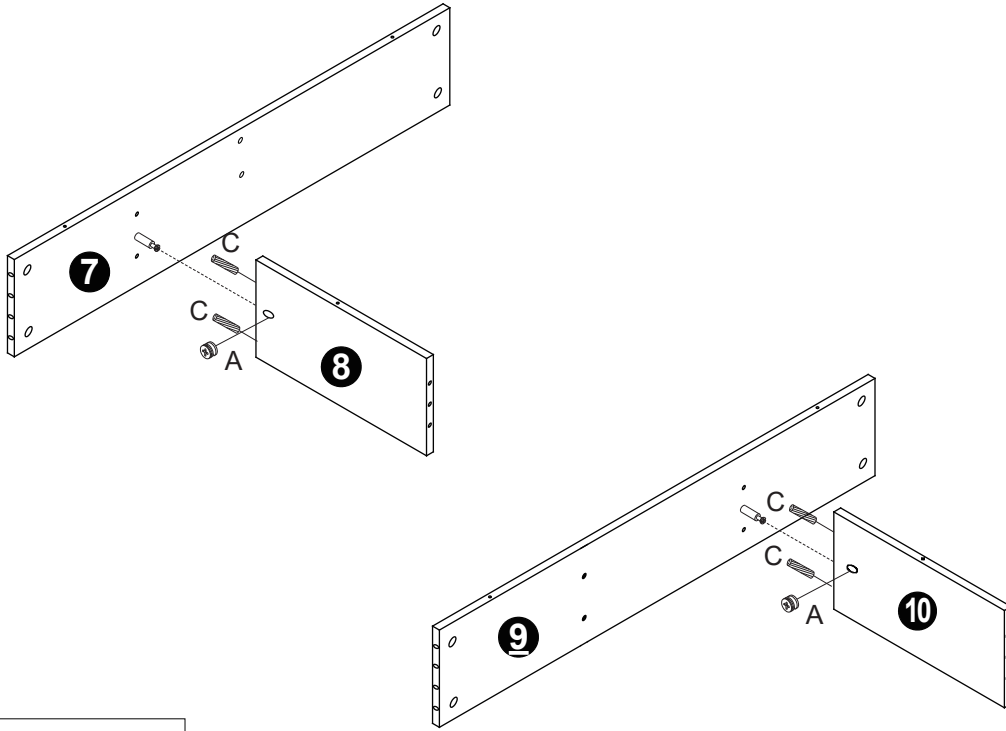

4

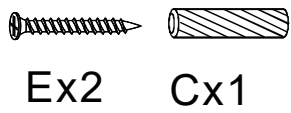
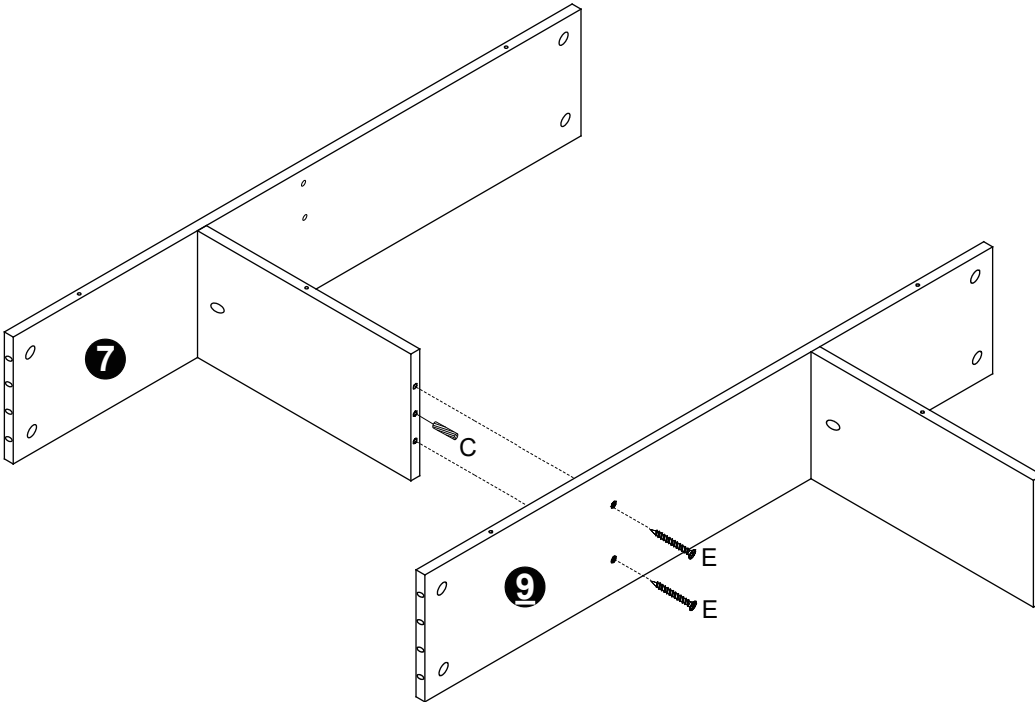

5

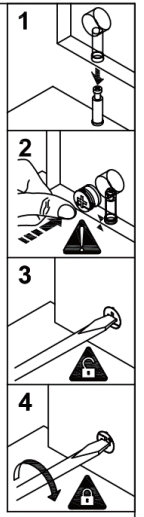
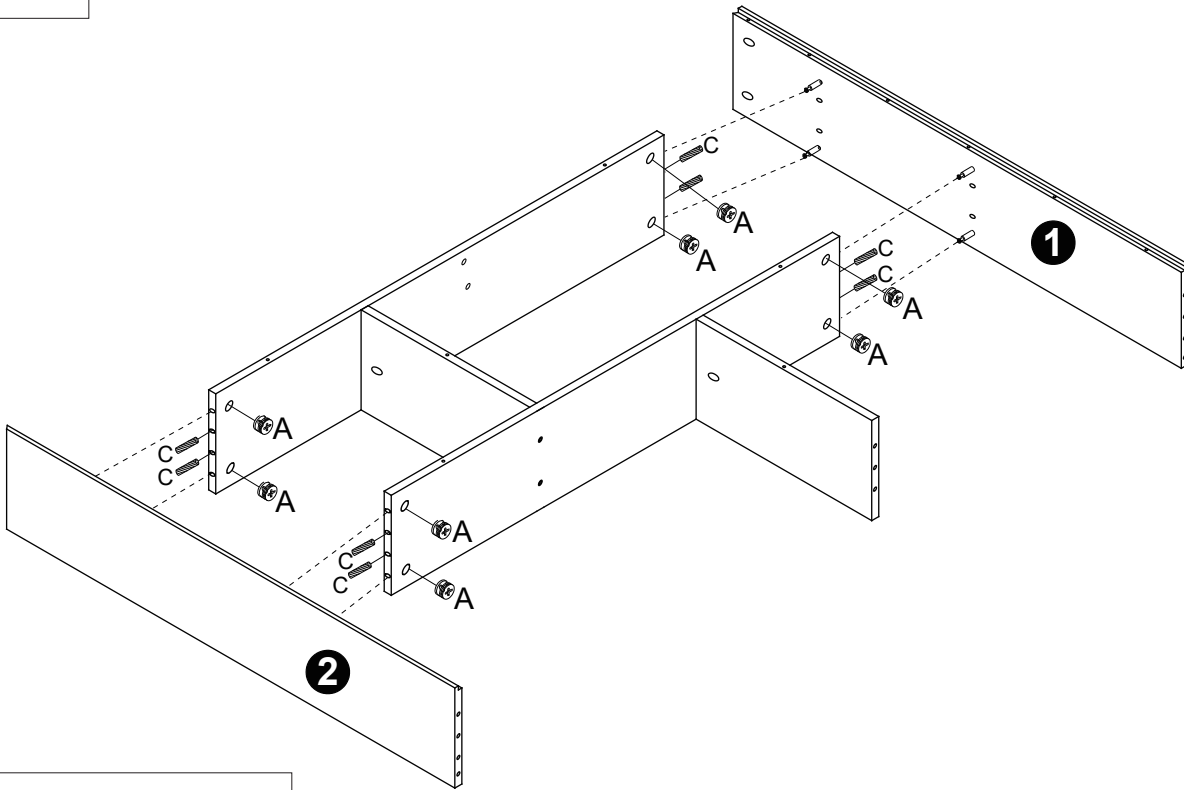

Ax8



Cx8

6

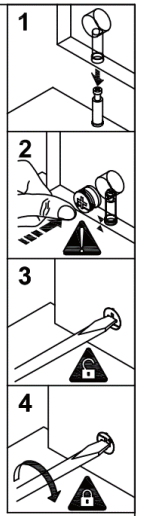
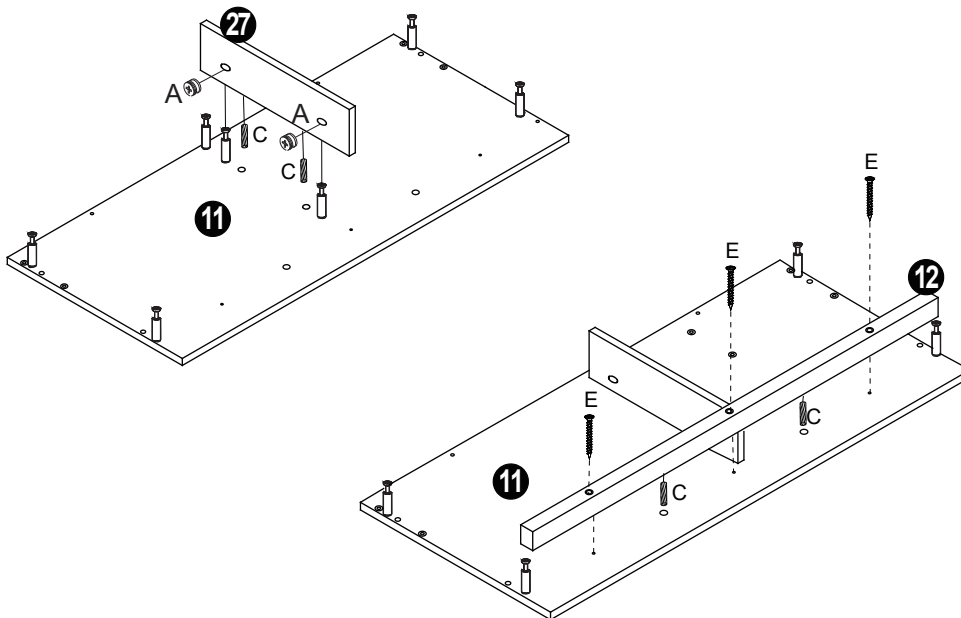

Cx4

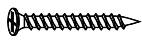

Ex3



Ax2

7

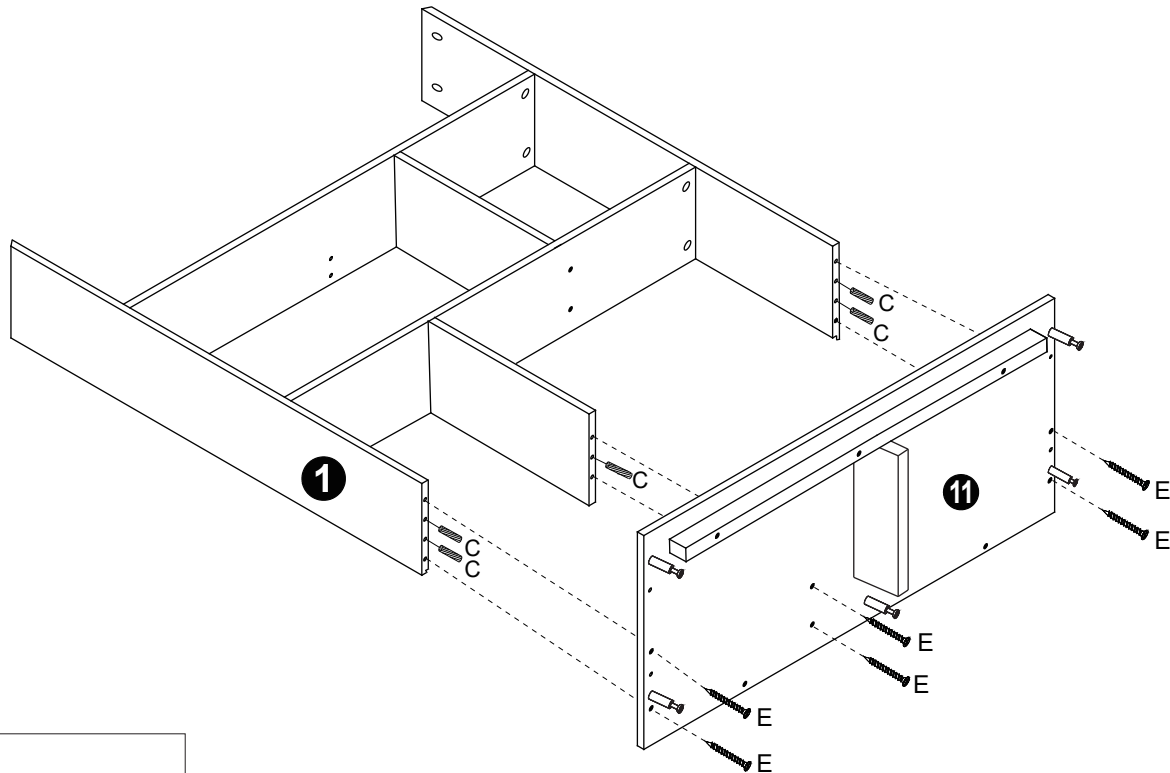

Ex6

Cx5

8

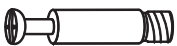
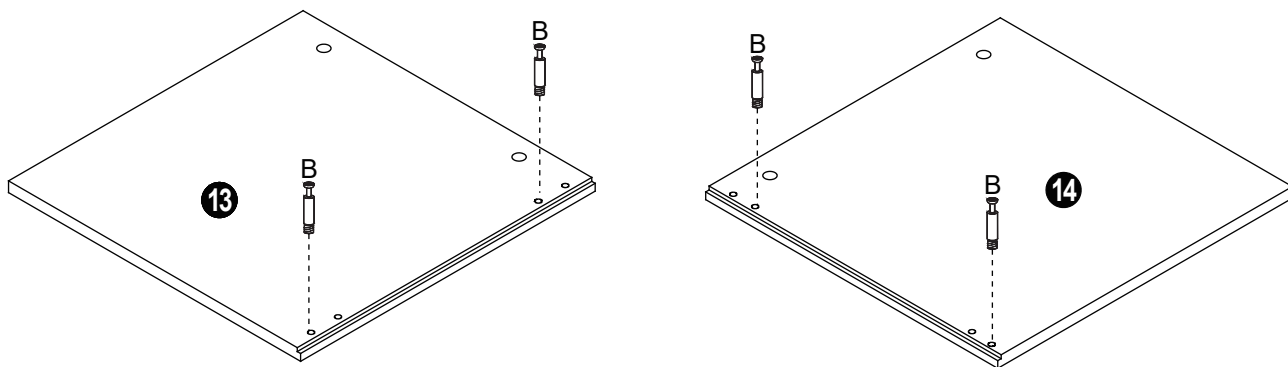

Bx4

9

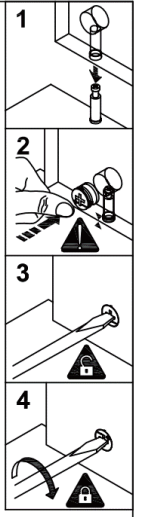
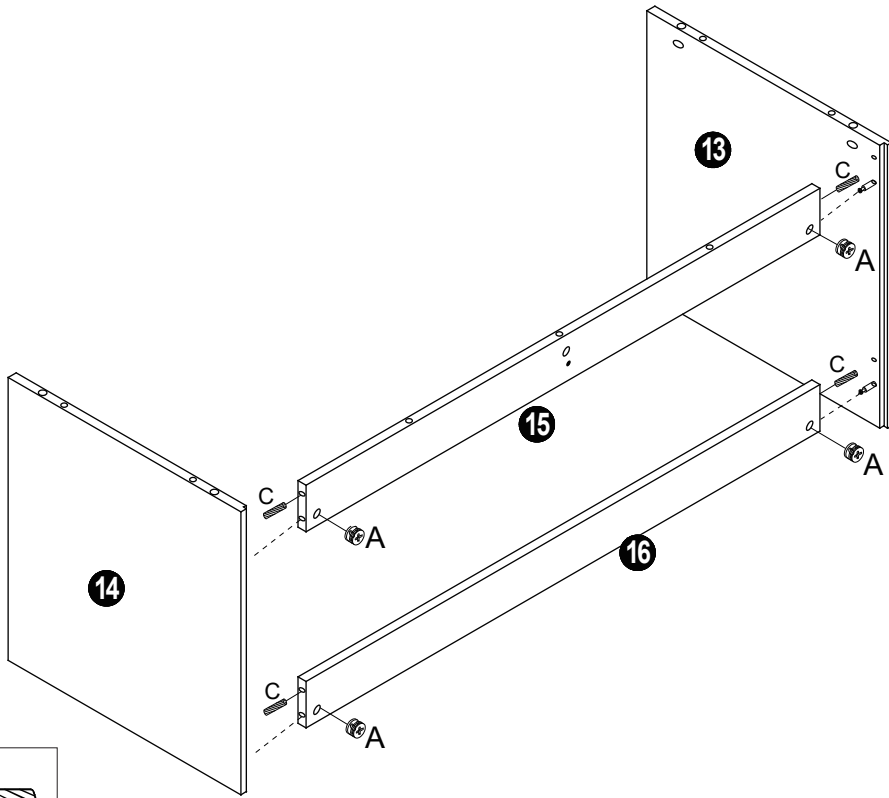

Ax4



Cx4

10

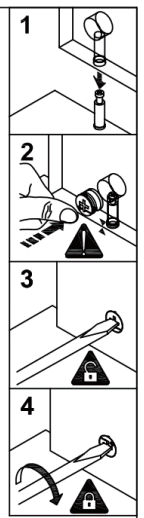
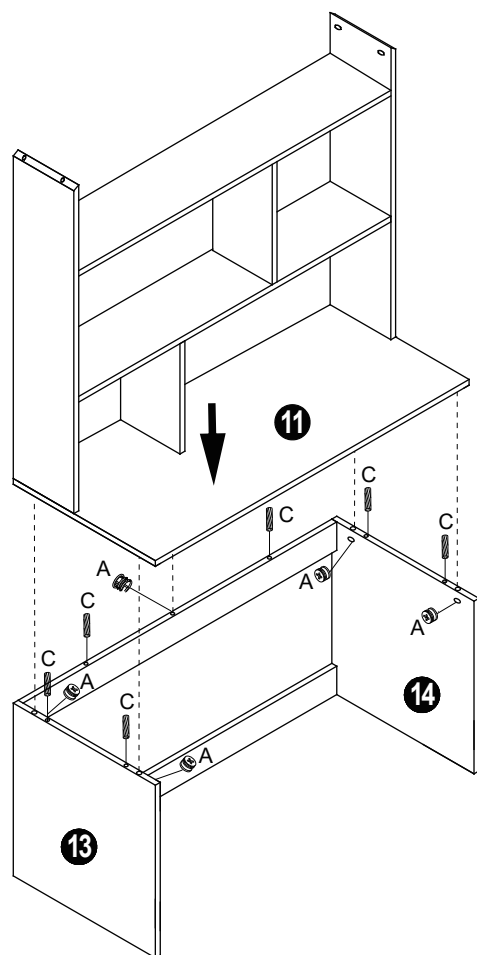

Ax5



Cx6

11

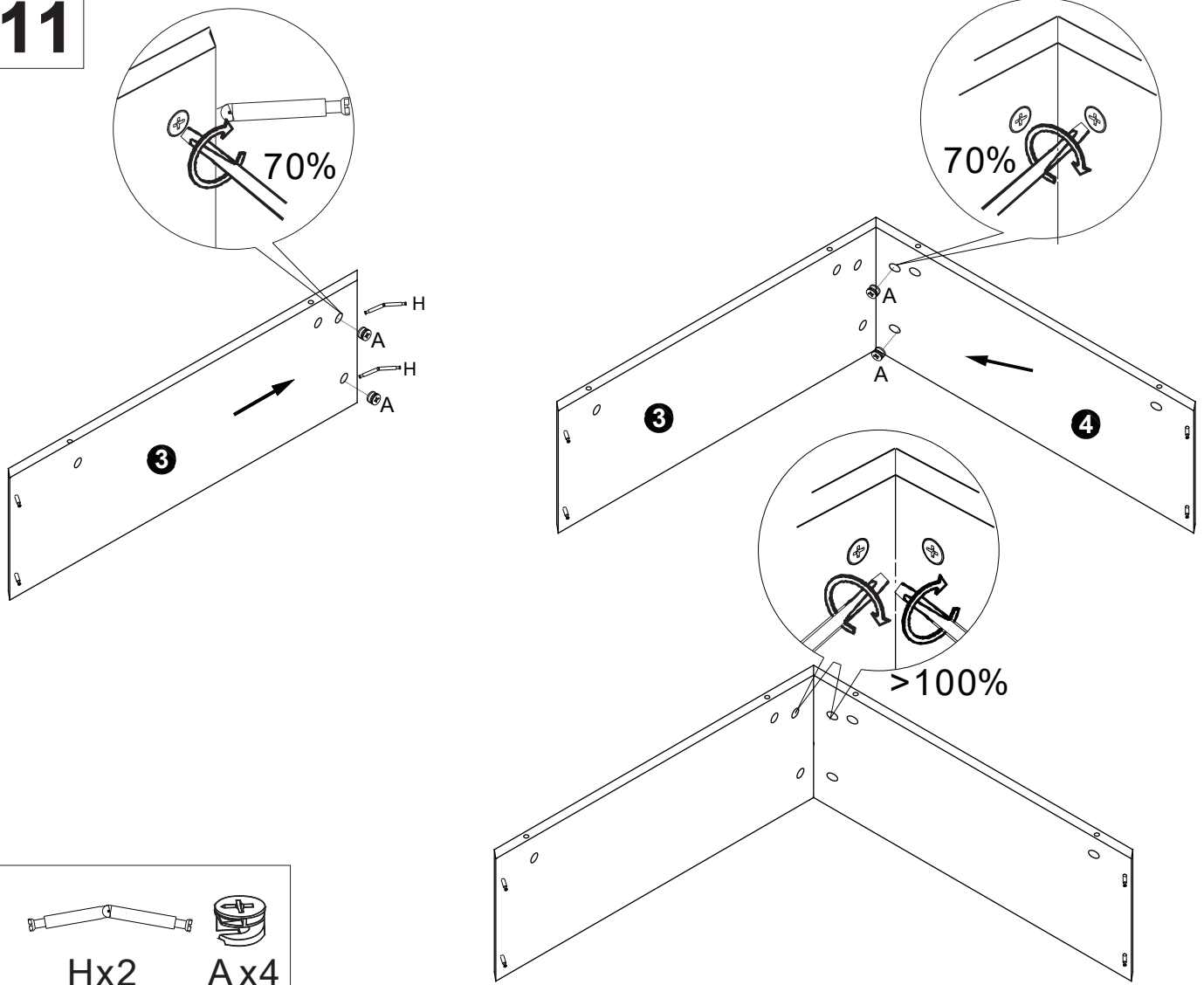

12

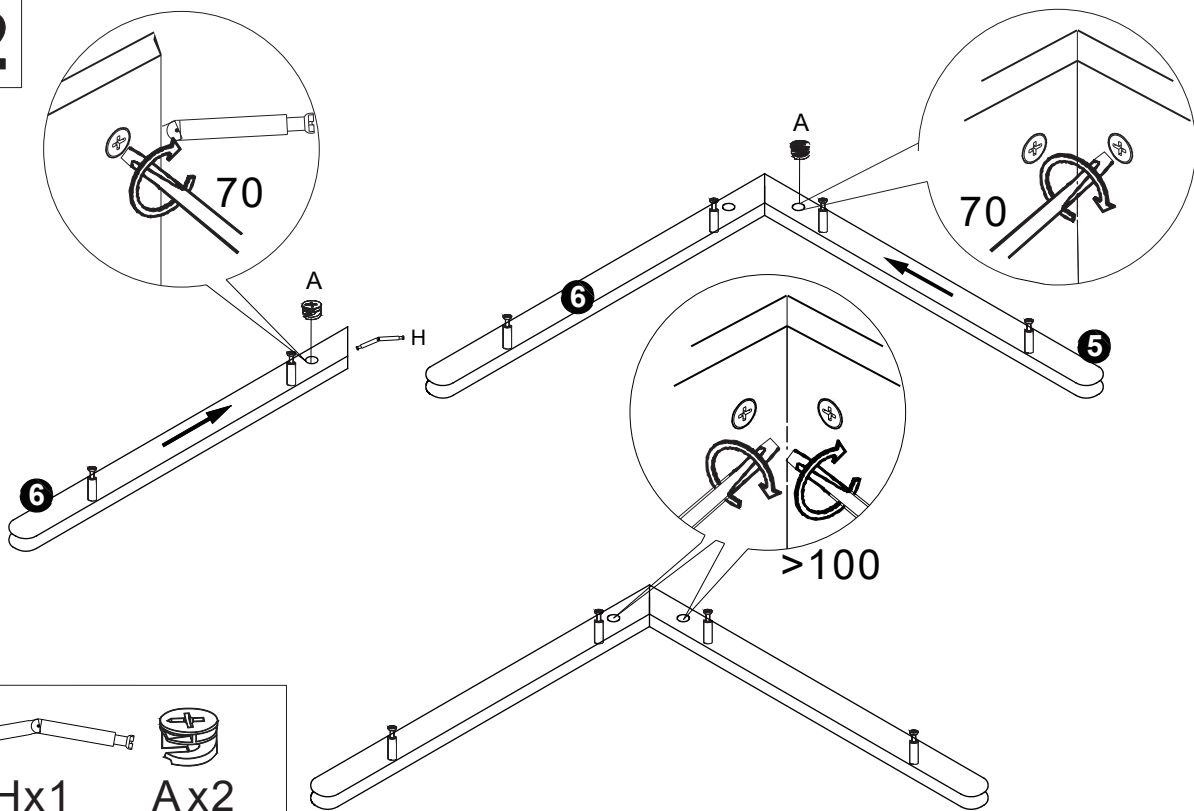

13

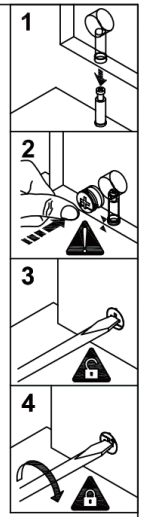
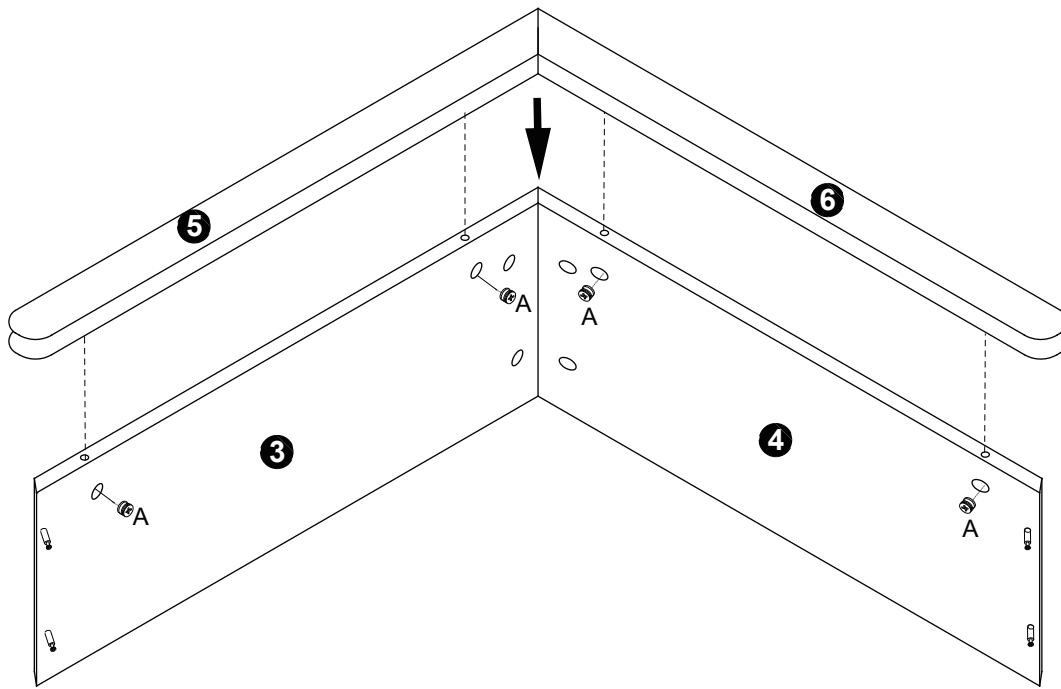

Ax4

14

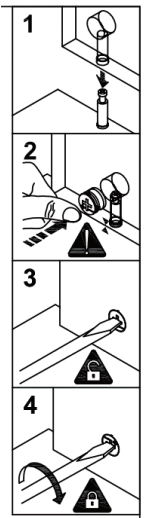
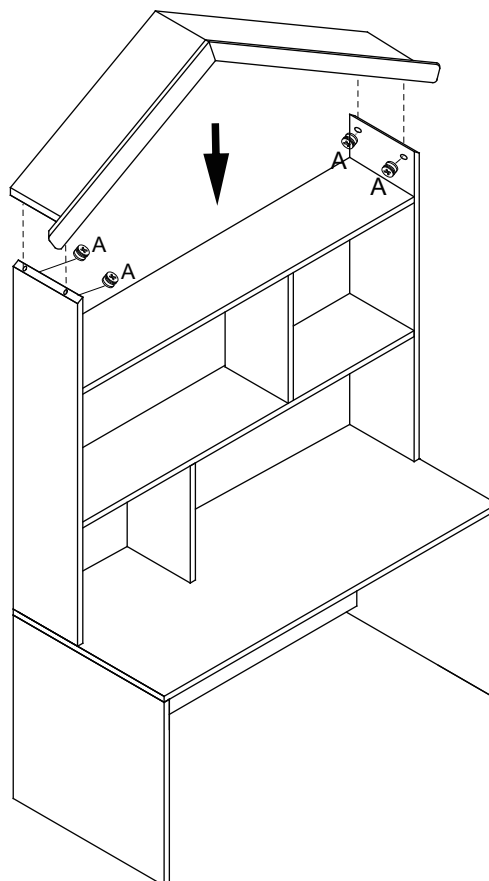

Ax4



15

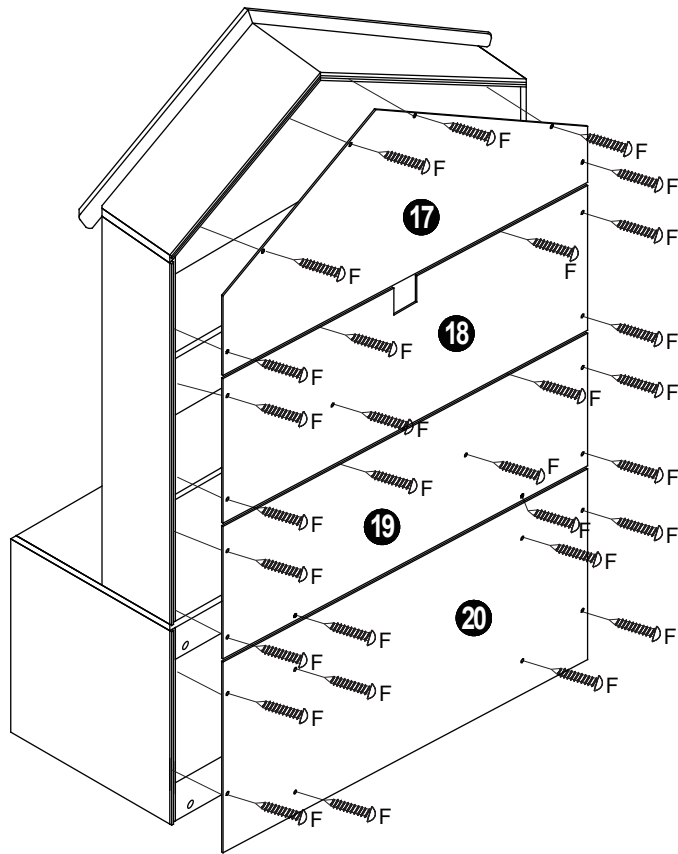

Fx30

16

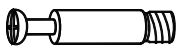
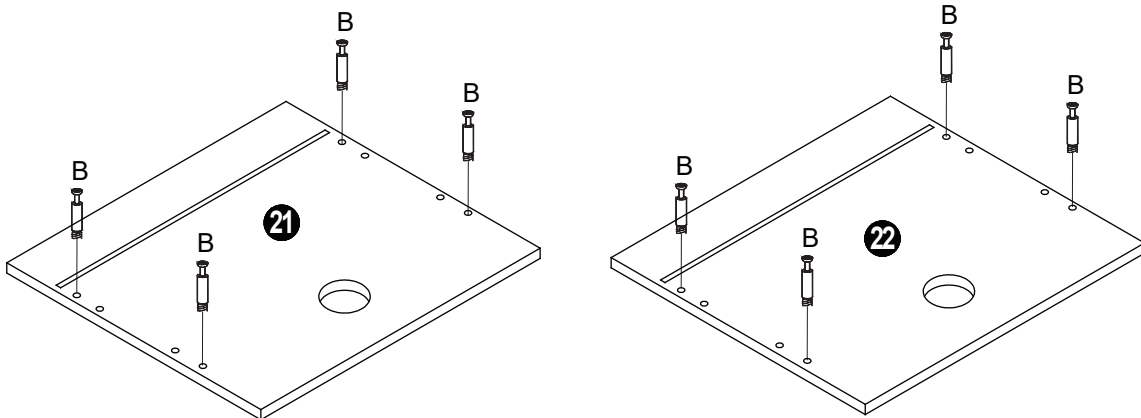

Bx8

17

x2

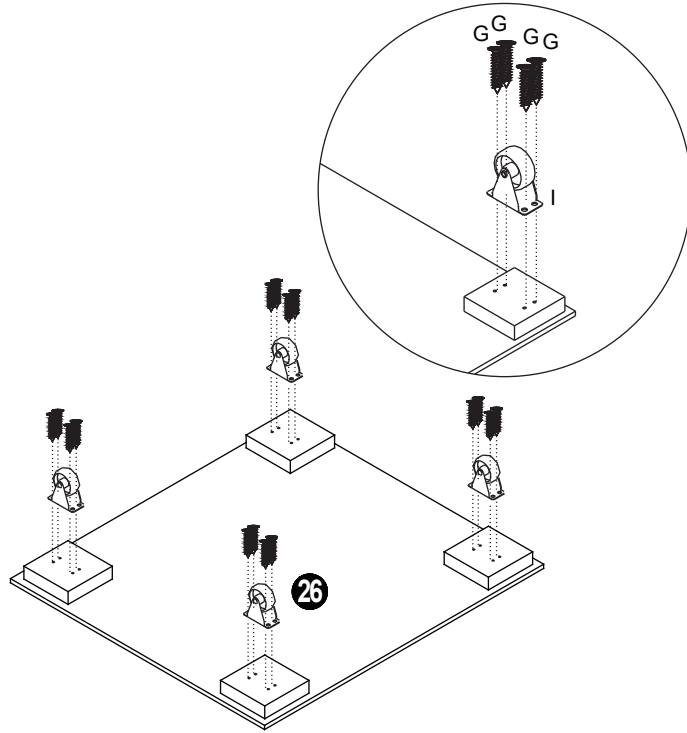

Gx32



Ix8

18

x2

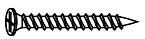
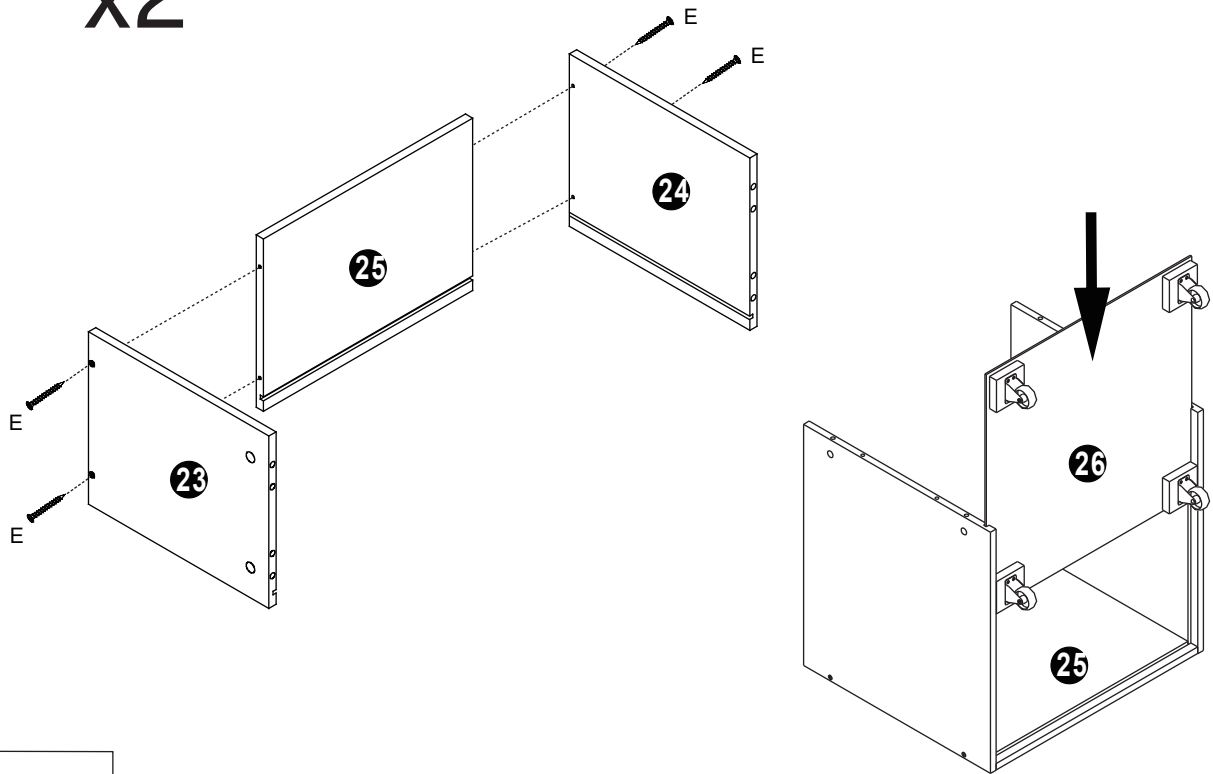

Ex8

# 19

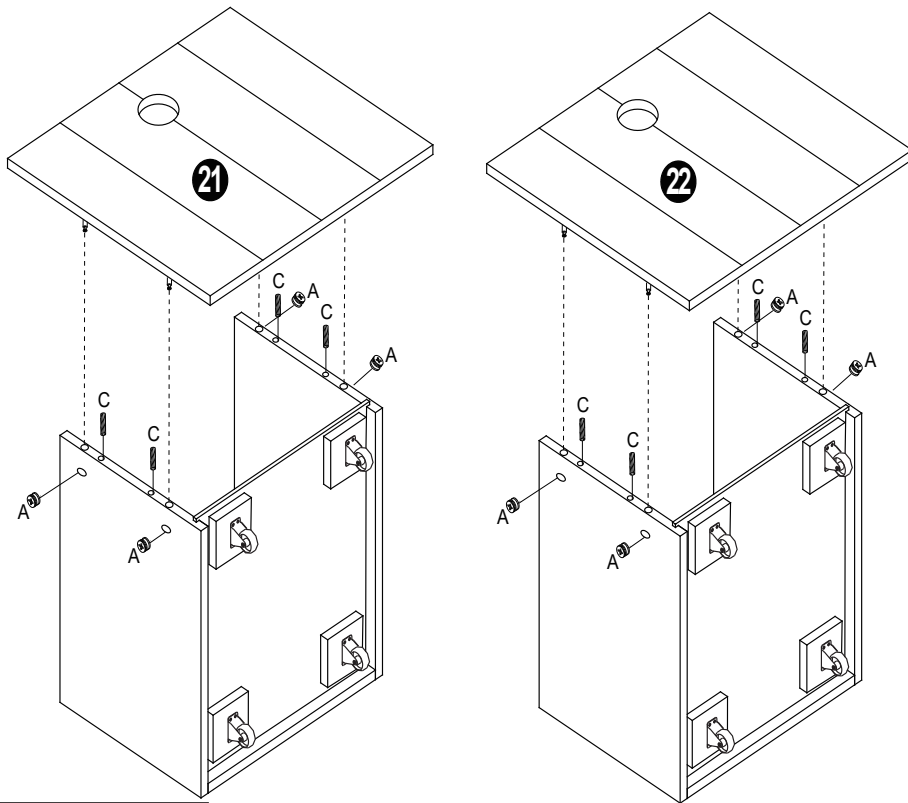

Cx8



Ax8

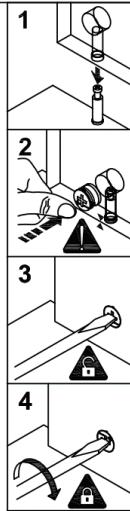

# 20

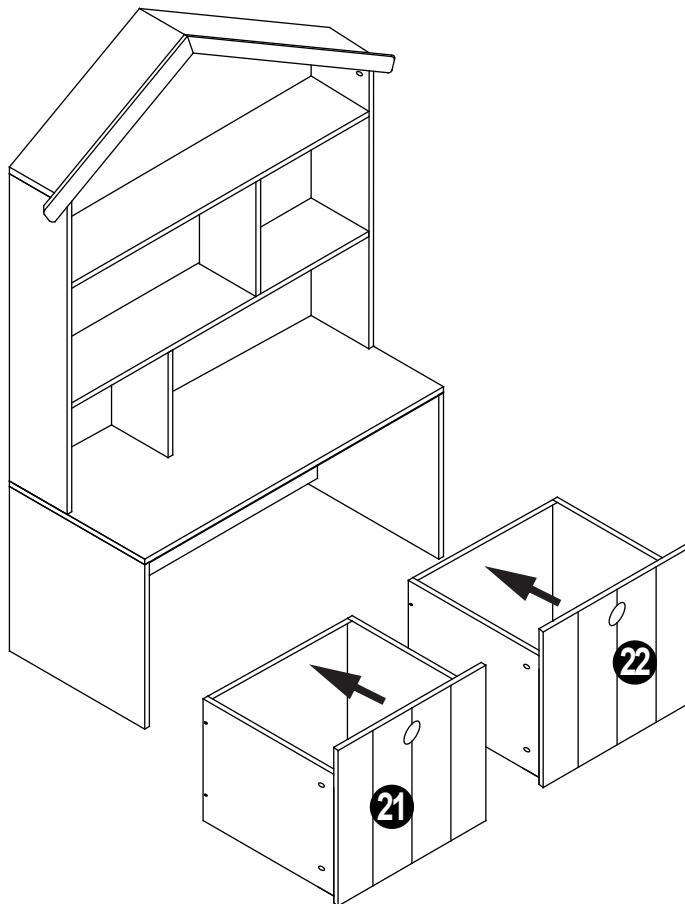

21

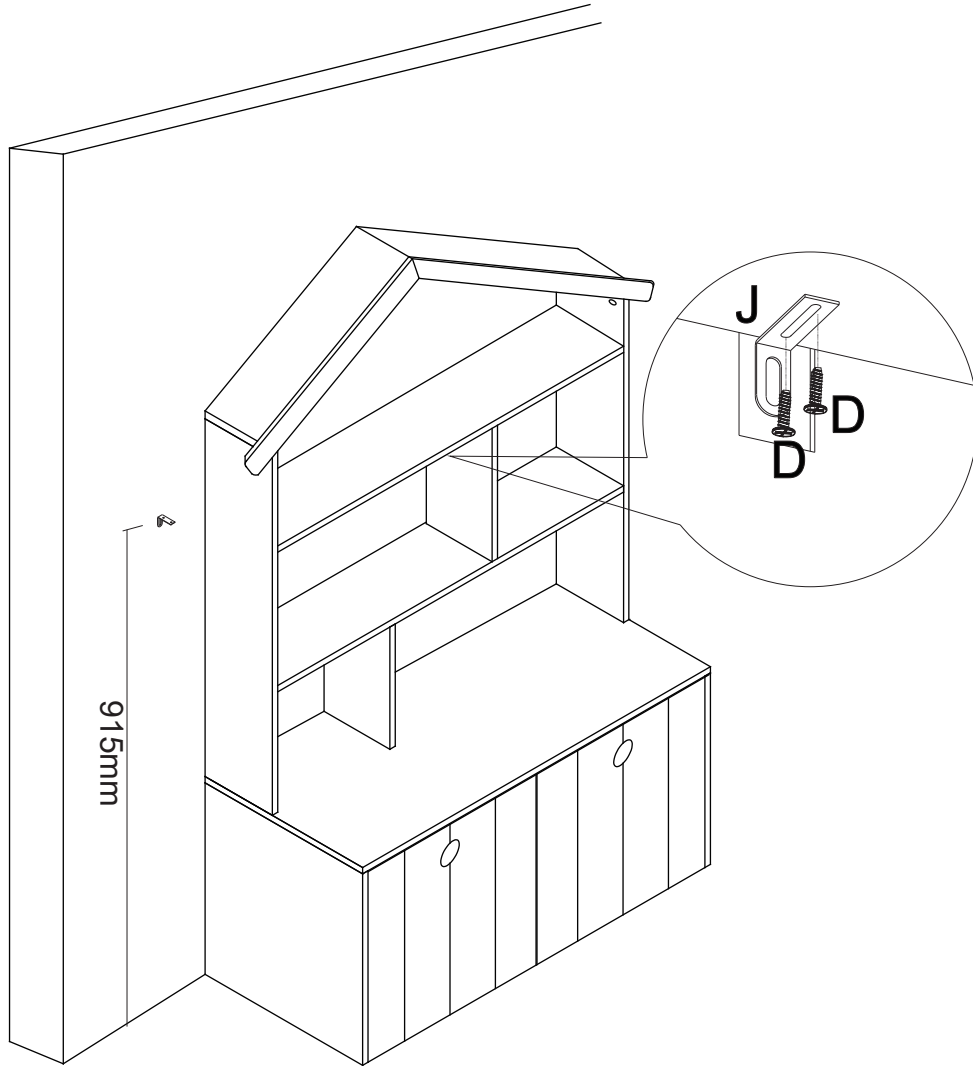

Dx2

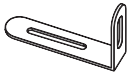

Jx1

**Importé par / Imported by / Importado por / Importado por / Importiert von / Importato da / Geïmporteerd door**

UE/EU: Verbaudet SAS - 216 Rue Winoc Chocqueel, 59200 Tourcoing, France

UK: Verbaudet UK Limited - Elder House, St Georges Business Park, 207 Brooklands Road, Weybridge, Surrey KT13 0TS

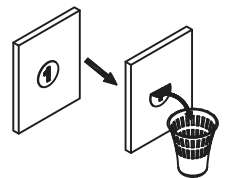
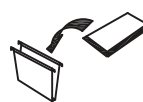

**FR – ATTENTION !**

Risque de blessure grave en cas de chute du meuble. Pour éviter que le meuble ne bascule, il faut le fixer au mur de façon permanente. Les fixations ne sont pas incluses car leur choix dépend du matériau du mur sur lequel est fixé le meuble. Utilisez des fixations adaptées au matériau du mur. Pour obtenir des conseils sur les fixations à utiliser, adressez-vous à un revendeur spécialisé.

**EN – WARNING !**

Serious or fatal crushing injuries can occur from furniture tip-over. To prevent this furniture from tipping over it must be permanently fixed to the wall. Fixing devices for the wall are not included since different wall materials require different types of fixing devices. Use fixing devices suitable for the walls in your home. For advice on suitable fixing systems, contact your local specialized dealer.

**PT – ATENÇÃO !**

As quedas de móveis podem originar esmagamento ou morte. Estes móveis devem ser fixados à parede para evitar possíveis quedas. Os diferentes tipos de parede requerem diferentes tipos de ferragens. Utilize ferragens adequadas às paredes da sua casa (não incluídas). Se não tiver a certeza do tipo de parafusos ou ferragem a usar, consulte uma loja de ferragens.

**ES - ¡ADVERTENCIA!**

Pueden producirse lesiones graves o fatales si vuelca un mueble. Para evitar que vuelque este mueble, debe fijarse permanentemente a la pared. No se incluyen los dispositivos de fijación, dado que los diversos materiales de pared requieren diferentes tipos de herrajes de fijación. Usa herrajes adecuados para el material de las paredes de tu casa. Para saber cuáles son los herrajes adecuados, pide consejo en tu ferretería habitual.

**DE – ACHTUNG !**

Wenn Möbelstücke umkippen, können ernste oder lebensgefährliche Verletzungen durch Einklemmen die Folge sein. Um zu verhindern, dass das Möbelstück umkippt, muss es fest an der Wand verankert werden. Beschläge für die Wandbefestigung sind nicht beige packt, da sie von der jeweiligen Wandbeschaffenheit abhängig sind. Befestigungsbeschläge benutzen, die für die heimischen Wände geeignet sind. Bei diesbezüglichen Fragen den örtlichen Fachhandel zu Rate ziehen.

**IT – ATTENZIONE !**

Se il mobile si ribalta può causare lesioni da compressione serie o fatali. Per prevenire il rischio che il mobile si ribalti, quest'ultimo deve essere fissato permanentemente alla parete. Gli accessori per il fissaggio alla parete non sono inclusi perché pareti di materiali diversi richiedono tipi diversi di accessori di fissaggio. Usa sistemi di fissaggio adatti alle pareti della tua casa. Per maggiori dettagli, rivolgiti a un rivenditore specializzato.

**NL – WAARSCHUWING !**

Er is risico op ernstig letsel in geval het meubel omvalt. Om te vermijden dat het meubel omvalt, maak het op een permanente wijze vast aan een muur. Er zijn geen bevestigingen inbegrepen, deze zijn namelijk afhankelijk van het materiaal van de muur waarop het meubel wordt vastgemaakt. Gebruik bevestigingen die voor het materiaal van de muur geschikt zijn. Voor advies over geschikte bevestigingen, neem contact op met uw vakbekwame verkoper.