

REF No: 1010820 0402

Version : 2023/06/29

Code FO : 9008002830



- FR** NOTICE DE MONTAGE
- EN** ASSEMBLY INSTRUCTIONS
- DE** MONTAGEANLEITUNG
- ES** INSTRUCCIONES DE MONTAJE
- NL** MONTAGEVOORSCHRIFT
- IT** ISTRUZIONI DI MONTAGGIO
- PT** INSTRUÇÕES DE MONTAGEM

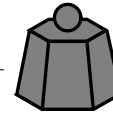

Max
19Kg / 41.9Lbs

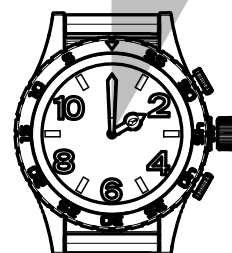
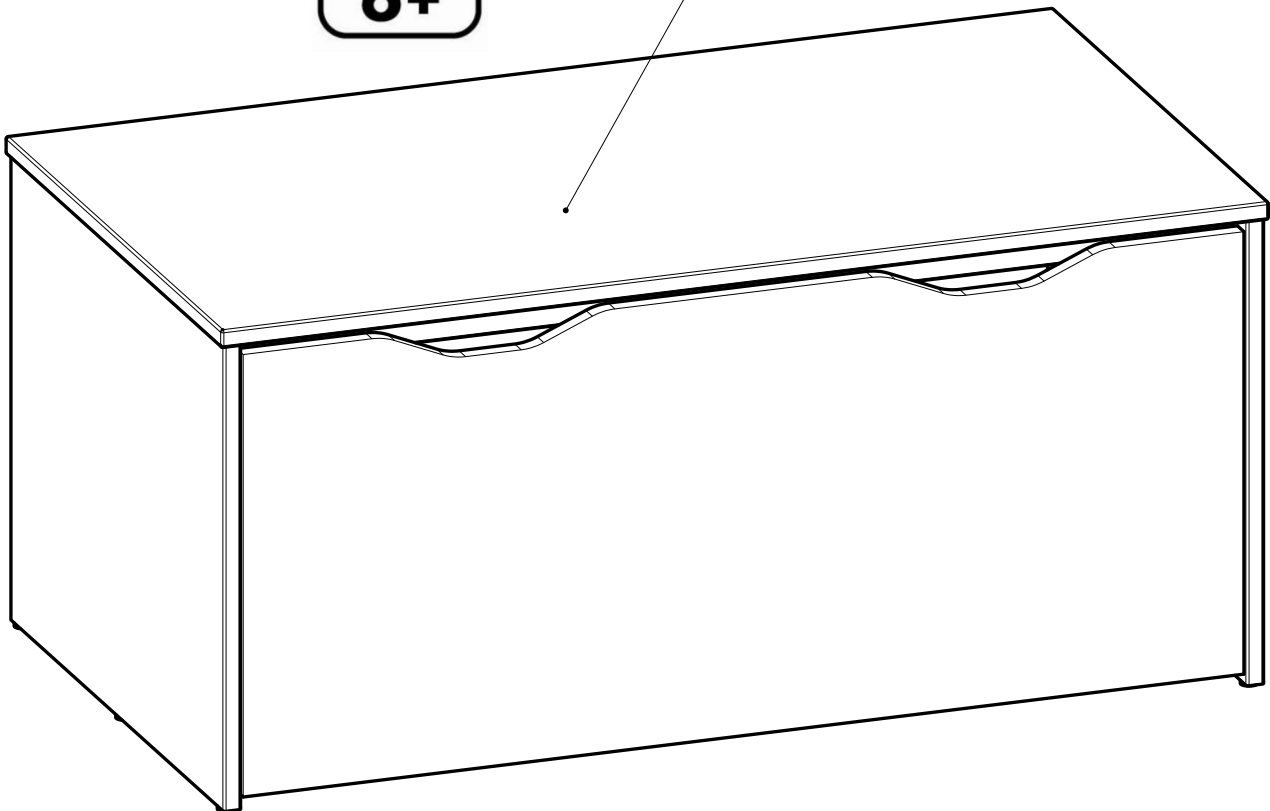

1hoo.



Fabriqué en France
Made in France

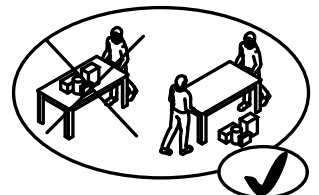
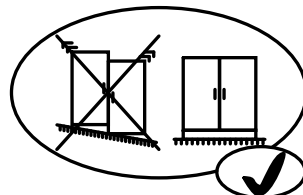
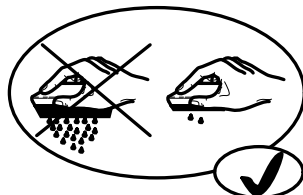
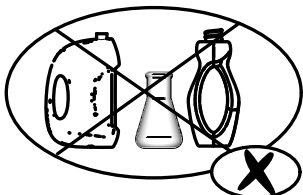
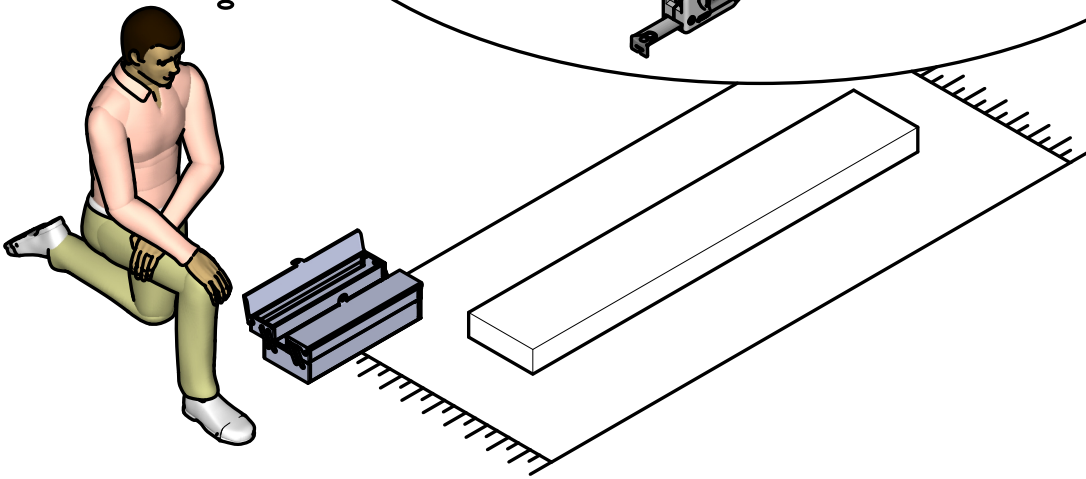
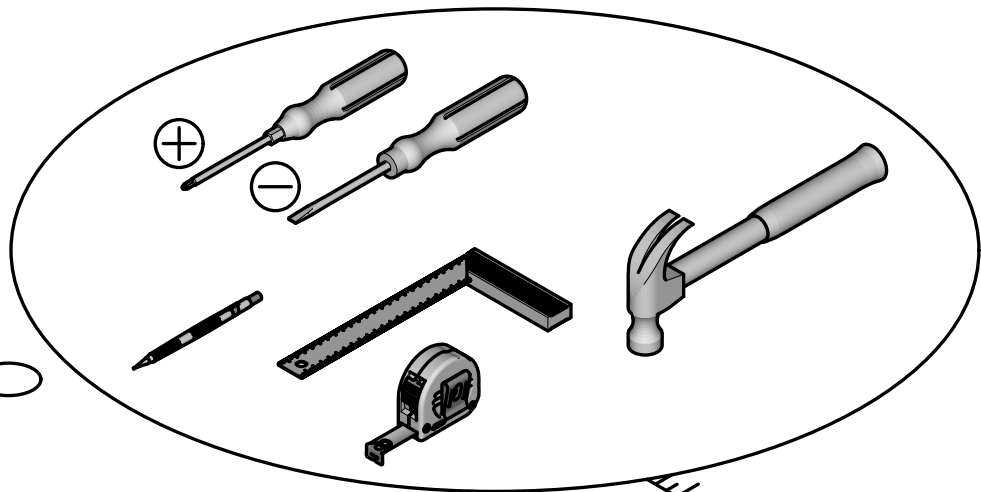
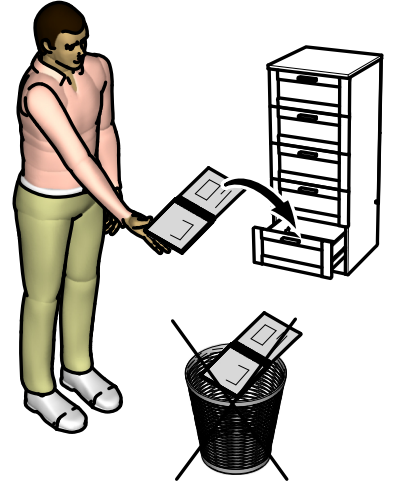
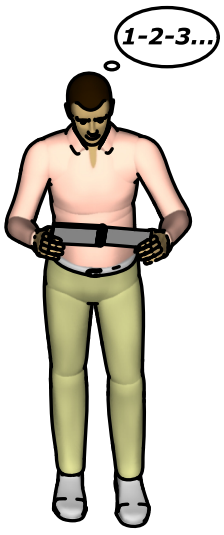



- **Vor montage den inhalt Ihres Päckens kontrollieren**
- **Die verpackung nicht zerstören, sie wird ihnen nützlich sein, um die teile bei der montage vor stößen und kratzen zu schützen**
- **Das Möbel dann in der reihenfolge der nummerierung zusammenbauen**
- **Im problemfall Ihren kundendienst anrufen**
- **Lüften sie Ihre möbel nach dem aufbau bitte mit geöffneten möbeltüren und-schubladen in einem gut durchlüfteten raum**



- **Controlar el contenido de su embalaje antes de proceder al montaje**
- **No deteriorar el paquete, que le será muy útil para proteger los elementos de golpes y rozaduras durante el montaje.**
- **Acoplar de seguida el mueble, siguiendo la orden definida por la numeración**
- **Si tiene problemas, contactar nuestro servicio postventa**
- **Desde la recepción, ventilar los muebles, con las puertas y cajones abiertos, en una estancia bien ventilada. Renovar regularmente el aire de las estancias**



- **Verificare il contenuto della confezione prima del montaggio.**
- **Non eliminare l'imballo che potrà essere utilizzato per proteggere il prodotto dai danni durante il montaggio.**
- **Montare l'articolo seguendo l'ordine di numerazione.**
- **In caso di necessita contattare il nostro servizio post-vendita.**
- **Al ricevimento, areare i vostri mobili, aprendo porte e cassetti, in una stanza ben ventilata. Ricambiare l'aria della stanza regolarmente**



- **De inhoud van uw pakket controleren alvorens met de montage te beginnen**
- **De verpakking niet beschadigen, deze kan heel handig zijn om de onderdelen te beschermen tegen schokken en krassen tijdens de montage.**
- **Zet vervolgens het meubel in elkaar in de volgorde die is bepaald in de nummering**
- **Neem bij problemen contact op met onze klantenservice**
- **Laat na ontvangst uw meubels luchten (deuren en laden open) in een goed geventileerde ruimte. Zorg regelmatig voor frisse lucht in uw kamer**



- **Controler le contenu de votre colis avant de procéder au montage.**
- **Ne détériorez pas l'emballage, il vous sera très utile pour protéger les éléments des coups et rayures pendant le montage.**
- **Assemblez ensuite le meuble en suivant l'ordre défini par la numérotation.**
- **En cas de problème contactez notre service après vente.**
- **A réception, aérer vos meubles, portes et tiroirs ouverts, dans une pièce bien ventilée. Renouveler régulièrement l'air de vos pièces.**



- **Check the content of your parcel before assembly.**
- **Do not throw away the packing which could be very useful to protect the panels from knocks and scratches when assembling.**
- **Assemble the article following the order of the numbers indicated.**
- **Should any problems arise, please contact our after sale service.**
- **Upon receipt, place the furniture in a well-ventilated room and leave doors and drawers open to allow the air to circulate. Change the air in your rooms on a regular basis.**



- **Confira o conteúdo da sua encomenda antes de iniciar a montagem.**
- **Não danifique a embalagem, poderá ser-lhe útil para proteger os elementos de golpes ou riscos durante a montagem.**
- **Proceda à montagem do móvel seguindo a ordem definida pela numeração.**
- **Para qualquer esclarecimento, contacte os nossos serviços através do telefone.**

- **Aquando da sua recepção, areje os seus móveis, portas e gavetas abertos, numa divisão bem ventilada. Renover regularmente o ar das suas divisões.**

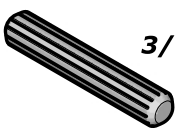
A x2  **5x30mm**
3/16" x 1 3/16"

G x2 

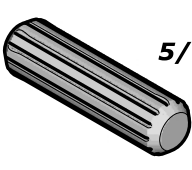
B x10  **8x30mm**
5/16" x 1 3/16"

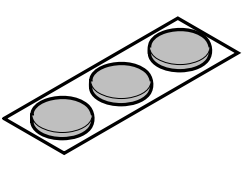
H x2 

C x8  **6,3x9mm**
1/4" x 11/32"

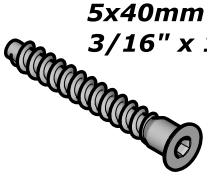
I x4  **5x40mm**
3/16" x 1 9/16"

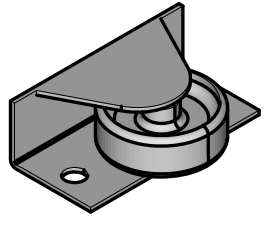
D x4 

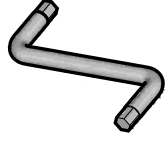
J x1 

E x16 

K x8  **Ø12mm**
Ø15/32"

F x10  **Ø15mm**
Ø19/32"

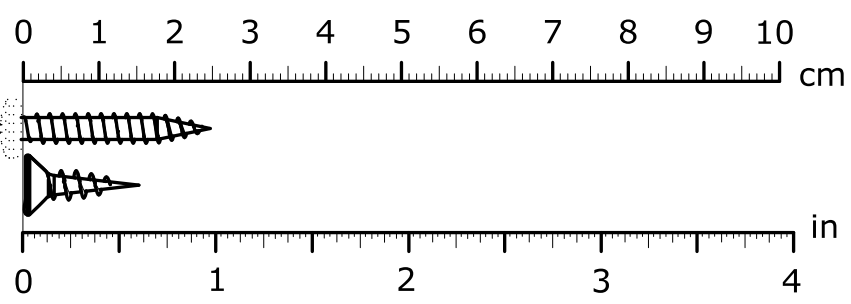

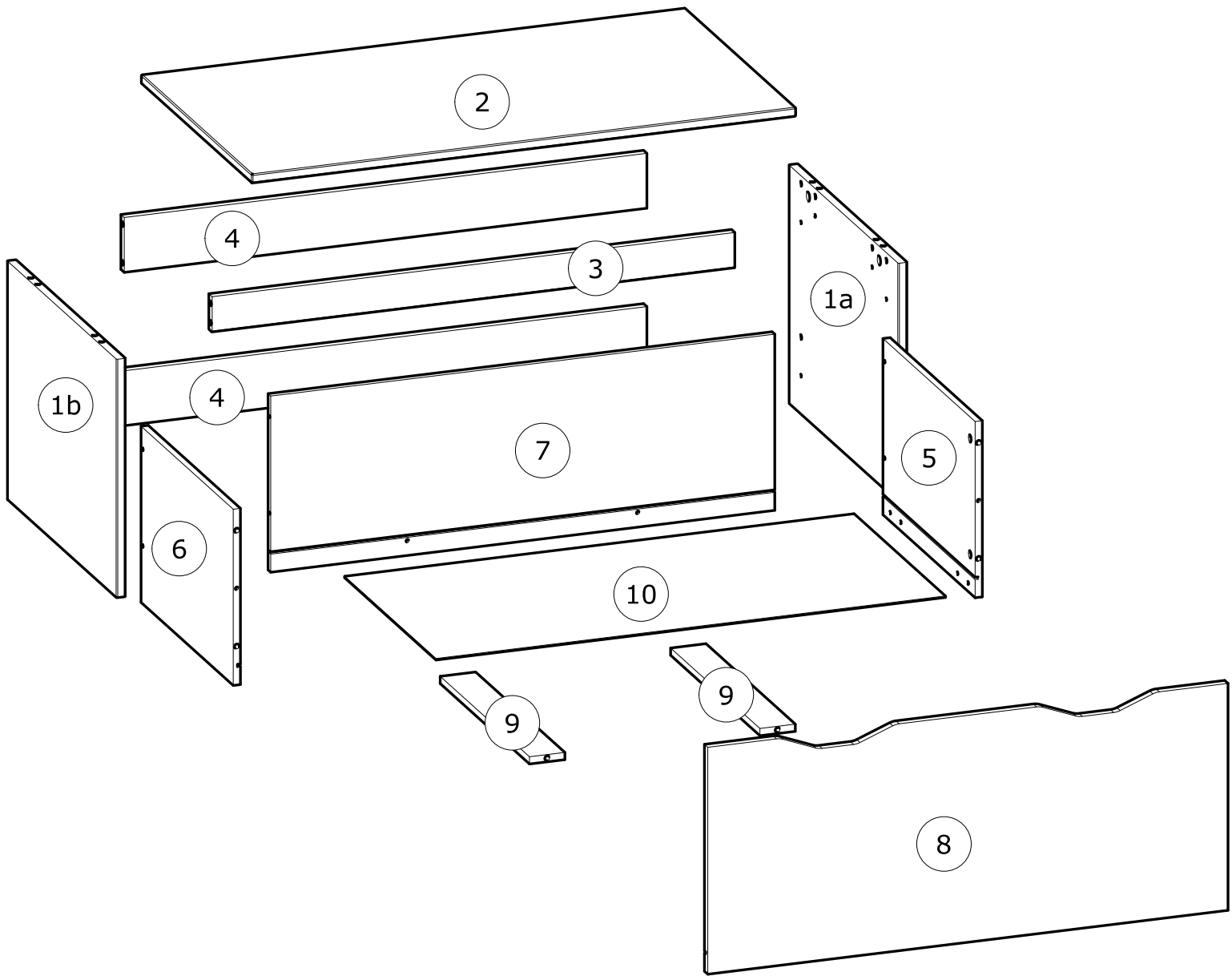

N°	MM		INCH		QTY
1	395	x 494	15 9/16	x 19 7/16	2
2	895	x 500	35 4/16	x 19 11/16	1
3	859	x 59	33 13/16	x 2 5/16	1
4	859	x 91	33 13/16	x 3 9/16	2
5	416	x 292	16 6/16	x 11 8/16	1

N°	MM		INCH		QTY
6	416	x 292	16 6/16	x 11 8/16	1
7	828	x 292	32 10/16	x 11 8/16	1
8	855	x 376	33 11/16	x 14 13/16	1
9	403	x 59	15 14/16	x 2 5/16	2
10	837	x 412	32 15/16	x 16 4/16	1

FR - IMPORTANT ! A LIRE ATTENTIVEMENT ET A CONSERVER EN VUE D'UNE CONSULTATION ULTERIEURE

- A monter par un adulte. Un adulte doit vérifier le bon assemblage avant l'emploi
- ATTENTION! tenir les vis et petits éléments et sachets hors de portée des enfants
- Bien identifier les éléments avant de commencer le montage
- En cas de problème contactez notre service après-vente
- Toujours suivre les instructions du fabricant
- Ne pas monter sur le produit
- Entretien: nettoyer avec un chiffon doux et sec. En cas de taches plus grosses, frottez soigneusement avec une éponge légèrement humide et non abrasive
- AVERTISSEMENT - Si ce produit est placé sous une fenêtre, il peut servir de marche à l'enfant et entraîner sa chute par la fenêtre
- AVERTISSEMENT - Tenir compte des risques engendrés par la présence de foyers ouverts ou autres sources de forte chaleur à proximité immédiate du produit
- AVERTISSEMENT - NE PAS placer ce produit à proximité d'une fenêtre où les cordons de stores ou de rideaux pourraient étrangler un enfant
- Il convient de toujours serrer correctement tous les dispositifs d'assemblage
- Ne pas utiliser ce produit si une pièce est cassée, déchirée ou manquante et utiliser uniquement des pièces de rechange approuvées par le fabricant
- Âge de l'enfant auquel le siège est destiné : ≥ 6 ans
- Conforme à la norme EN 17191 :2021
- Charge maximale : 75 kg
- AVERTISSEMENT - Risque de trébuchement ou points de pincement pour les pieds

EN - IMPORTANT! READ CAREFULLY AND KEEP FOR FUTURE REFERENCE

- To be assembled by an adult. Assembly must be checked by an adult before use
- WARNING! keep all screws, small parts and plastic bags out of the reach of children
- Properly identify all parts before assembling
- Should any problems arise, please contact our After Sales Service
- Manufacturer's instructions shall be followed at all times
- Do not climb on the product
- Care: clean with a soft, dry cloth. In case of larger stains, carefully rub with a slightly damp, non-abrasive sponge
- WARNING - If this product is located under a window, it can be used as a step by the child and cause the child to fall out of the window
- WARNING - Be aware of the risk of open fires and other sources of strong heat in the vicinity of the product
- WARNING - DO NOT place this product near a window where cords from blinds or curtains may strangle a child
- All assembly fittings should always be tightened properly
- Do not use the product if any part is broken, torn or missing and use only spare parts approved by the manufacturer
- Age of the child for which the seating is intended: ≥ 6 years
- Complies with standard EN 17191 :2021
- Maximum loading : 75 kg
- WARNING - Tripping hazard or pinching points for feet

PT - IMPORTANTE! LEIA ATENTAMENTE E GUARDE PARA CONSULTA FUTURA

- A ser montado por um adulto. Um adulto deve verificar a boa montagem antes da utilização
- ATENÇÃO! mantenha os parafusos, acessórios pequenos e saco de plástico fora do alcance das crianças
- Identifique bem os acessórios antes de começar a montagem
- Para qualquer esclarecimento, contacte os nossos serviços através do telefone
- As instruções do fabricante devem ser sempre cumpridas
- Não suba para cima do produto
- Manutenção: limpe com um pano macio e seco. Em caso de manchas maiores, esfregue cuidadosamente com uma esponja ligeiramente húmida e não abrasiva
- AVISO - Se este produto for colocado sob uma janela, pode servir de degrau à criança e fazer com que caia da janela
- AVISO - Tenha em conta os riscos provocados pela presença de chamas livres e outras fontes de calor intenso na proximidade do produto
- AVISO - NÃO coloque este produto na proximidade de uma janela onde as fitas das persianas ou das cortinas possam estrangular a criança
- Todos os acessórios de montagem devem ser sempre fixados corretamente
- Não utilize este produto se uma peça estiver partida, rasgada ou em falta e utilize apenas peças de substituição aprovadas pelo fabricante
- Idade da criança à qual o assento se destina: ≥ 6 anos
- Em conformidade com a Norma EN 17191 :2021
- Carga máxima: 75 kg
- ADVERTÊNCIA - Risco de tropeçar ou pontos de aperto para os pés

ES - ¡IMPORTANTE! LEA DETENIDAMENTE ESTAS INDICACIONES Y GUÁRDELAS PARA FUTURAS CONSULTAS

- A montar por un adulto. Un adulto debe comprobar el buen montaje antes de la utilización
- ¡ADVERTENCIA! mantener los tornillos, los pequeños elementos y bolsitas fuera del alcance de los niños
- Identificar debidamente los elementos antes de empezar el montaje
- Si tiene problemas, contactar nuestro servicio postventa
- Deben seguirse siempre las instrucciones del fabricante
- No subir sobre el producto
- Cuidados: limpiar con un paño suave y seco. En caso de manchas grandes, frotar con cuidado utilizando una esponja húmeda no abrasiva
- ADVERTENCIA: Si se coloca el producto bajo una ventana, el niño podría subirse y caer por la ventana
- ADVERTENCIA: Tenga en cuenta el riesgo que generan las llamas abiertas y otras fuentes de calor intenso cerca del producto
- ADVERTENCIA: NO coloque este producto cerca de una ventana donde los cordones de los estores o de las cortinas puedan estrangular a un niño
- Todos los elementos de montaje deberán estar siempre correctamente apretados
- No utilice el producto si alguna pieza está rota, rasgada o falta; y utilice únicamente piezas de repuesto aprobadas por el fabricante
- Edad del niño o la niña a quien se destina el asiento: ≥ 6 años
- Conforme a la norma EN 17191 :2021
- Carga máxima : 75 kg
- ADVERTENCIA: Riesgo de tropiezo o puntos de aplastamiento para los pies

DE - WICHTIG! AUFMERKSAM LESEN UND FÜR SPÄTERES NACHLESEN AUFBEWAHREN

- Von einem Erwachsenen zu montieren. Die korrekte Montage muss vor Gebrauch von einem Erwachsenen geprüft werden
- ACHTUNG! die Schrauben und kleinen Teile ausserhalb der Reichweite von Kindern lagern
- Vor Montagebeginn alle Teile identifizieren
- Im Problemfall Ihren Kundendienst anrufen
- Stets die Herstelleranweisungen beachten
- Nicht auf das Produkt steigen
- Wartung: Mit einem weichen, trockenen Tuch reinigen. Bei größeren Flecken vorsichtig mit einem leicht feuchten, nicht scheuernden Schwamm abreiben
- WARNHINWEIS - Wenn das Produkt unter einem Fenster steht, kann es von einem Kind als Stufe genutzt werden und dazu führen, dass das Kind aus dem Fenster stürzt.
- WARNHINWEIS - Achten Sie auf Risiken, die durch offene Kamine oder andere starke Hitzequellen in der Nähe des Produkts entstehen können.
- WARNHINWEIS - Dieses Produkt nicht in der Nähe eines Fensters aufstellen, wo die Kordeln von Rollos oder Vorhängen eine Strangulationsgefahr für ein Kind darstellen.
- Alle Befestigungen sollten immer ordnungsgemäß festgezogen werden.
- Dieses Produkt nicht benutzen, wenn ein Teil gebrochen, gerissen ist oder fehlt. Nur vom Hersteller zugelassene Ersatzteile verwenden.
- Alter des Kindes, für das die Sitz bestimmt ist: ≥ 6 Jahre
- Entspricht der Norm EN 17191 :2021
- Höchstlast : 75 kg
- WARNUNG - Stolpergefahr oder Quetschstellen für die Füße

IT - IMPORTANTE! LEGGERE CON ATTENZIONE E CONSERVARE PER FUTURO RIFERIMENTO

- Il montaggio deve essere eseguito da un adulto. Un adulto dovrà verificare il corretto montaggio prima dell'uso
- ATTENZIONE! tenere le viti ed i componenti di piccole dimensioni lontano dalla portata dei bambini
- Controllare i pezzi prima del montaggio
- In caso di necessità contattare il nostro servizio post-vendita
- Seguire sempre le istruzioni del costruttore
- Non salire sul prodotto
- Manutenzione: pulire con un panno morbido e asciutto. Per le macchine più grandi, strofinare accuratamente con una spugna leggermente umida e non abrasiva
- AVVERTENZA - Se questo prodotto è collocato sotto una finestra, può essere utilizzato dal bambino come base per arrampicarsi, con conseguente rischio di caduta dalla finestra
- AVVERTENZA - Tenere conto dei rischi connessi alla presenza di fiamme libere o altre fonti di forte calore nelle vicinanze del prodotto.
- AVVERTENZA - NON mettere questo prodotto vicino a una finestra perché i cordoni di tende o veneziane potrebbero comportare il rischio di strangolamento
- Stringere correttamente tutti i dispositivi di fissaggio
- Non utilizzare il prodotto se uno dei suoi componenti è rotto, danneggiato o mancante e utilizzare solo parti di ricambio approvate dal costruttore.
- Età del bambino al quale è destinato il prodotto: ≥ 6 anni
- Conforme alla norma EN 17191 :2021
- Carico massimo : 75 kg
- ATTENZIONE - Rischio di inciampo o di pizzicamento dei piedi

NL BELANGRIJK! BELANGRIJK! AANDACHTIG DOORLEZEN EN BEWAREN VOOR LATERE RAADPLEGING

- Moet door een volwassene worden gemonteerd. Voor gebruik moet een volwassene controleren dat het product goed in elkaar is gezet
- WAARSCHUWING! schroeven en kleine elementen en zakjes buiten bereik van kinderen houden
- De elementen goed identificeren alvorens met de montage te beginnen
- Neem bij problemen contact op met onze klantenservice
- Volg altijd de instructies van de fabrikant
- Niet op het product klimmen
- Onderhoud: maak schoon met een zachte en droge doek. In geval van grotere vlekken, veeg voorzichtig schoon met een licht bevochtigde en niet-schurende spons
- WAARSCHUWING - Als dit product onder een raam wordt geplaatst, kan het door een kind als opstapje worden gebruikt waardoor het kind uit het raam kan vallen.
- WAARSCHUWING - Houd rekening met de risico's veroorzaakt door open vuren en andere sterke warmtebronnen in de nabijheid van het product
- WAARSCHUWING - Plaats dit product NIET in een buurt van een raam waar het koord van een jaloezie of gordijn een kind kan wurgen
- Zorg dat alle bevestigingen op elk moment juist zijn vastgemaakt.
- Gebruik dit product niet als er een onderdeel stuk of gescheurd is of ontbreekt. Gebruik alleen reserveonderdelen die door de fabrikant zijn goedgekeurd
- Leeftijd van het kind waarvoor de zitting is bestemd: ≥ 6 jaar
- Volgens EN 17191 :2021 norm
- Maximale belasting : 75 kg
- WAARSCHUWING - Gevaar op struikelen of knellingspunten voor de voeten



www.vertbaudet.com

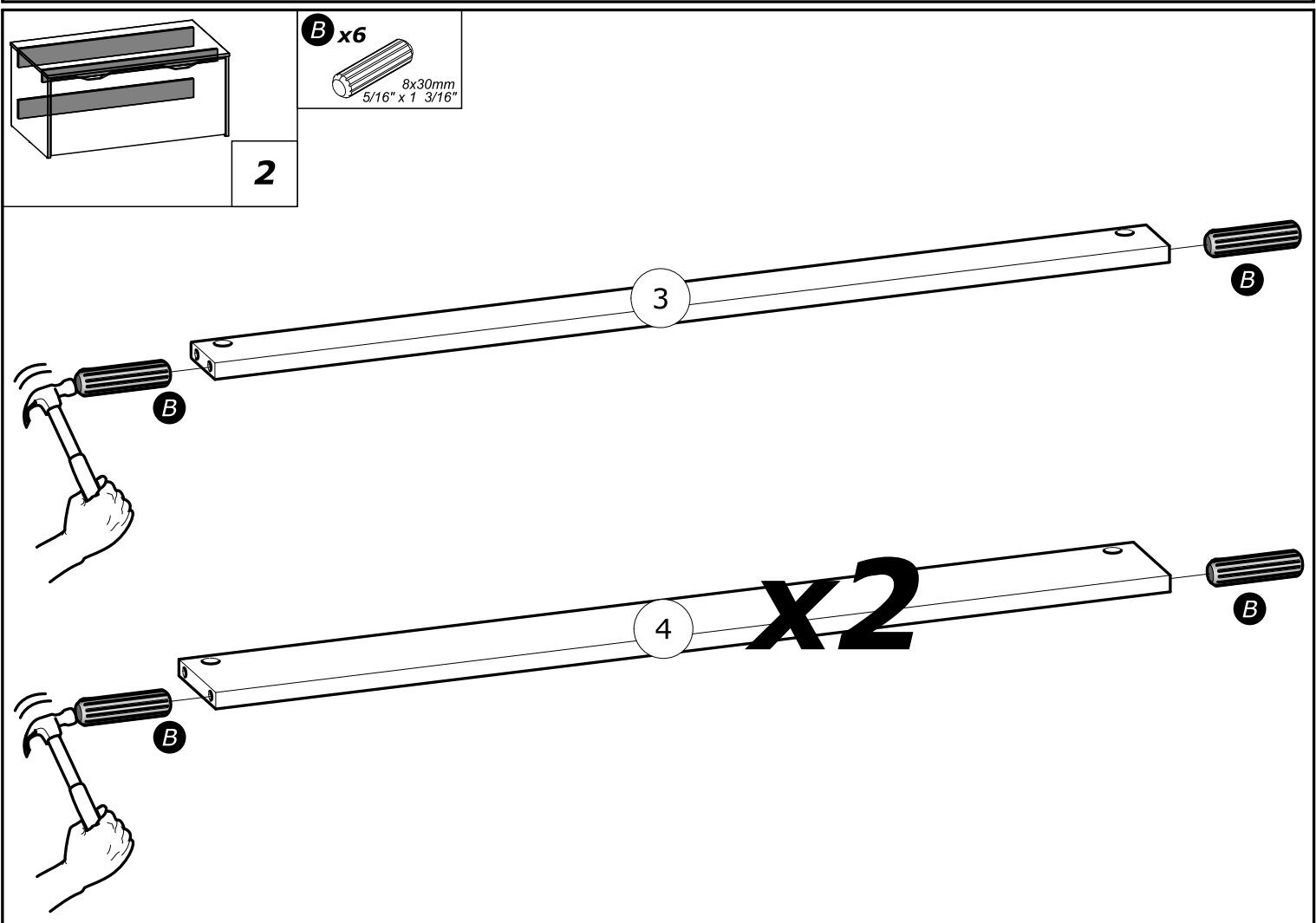
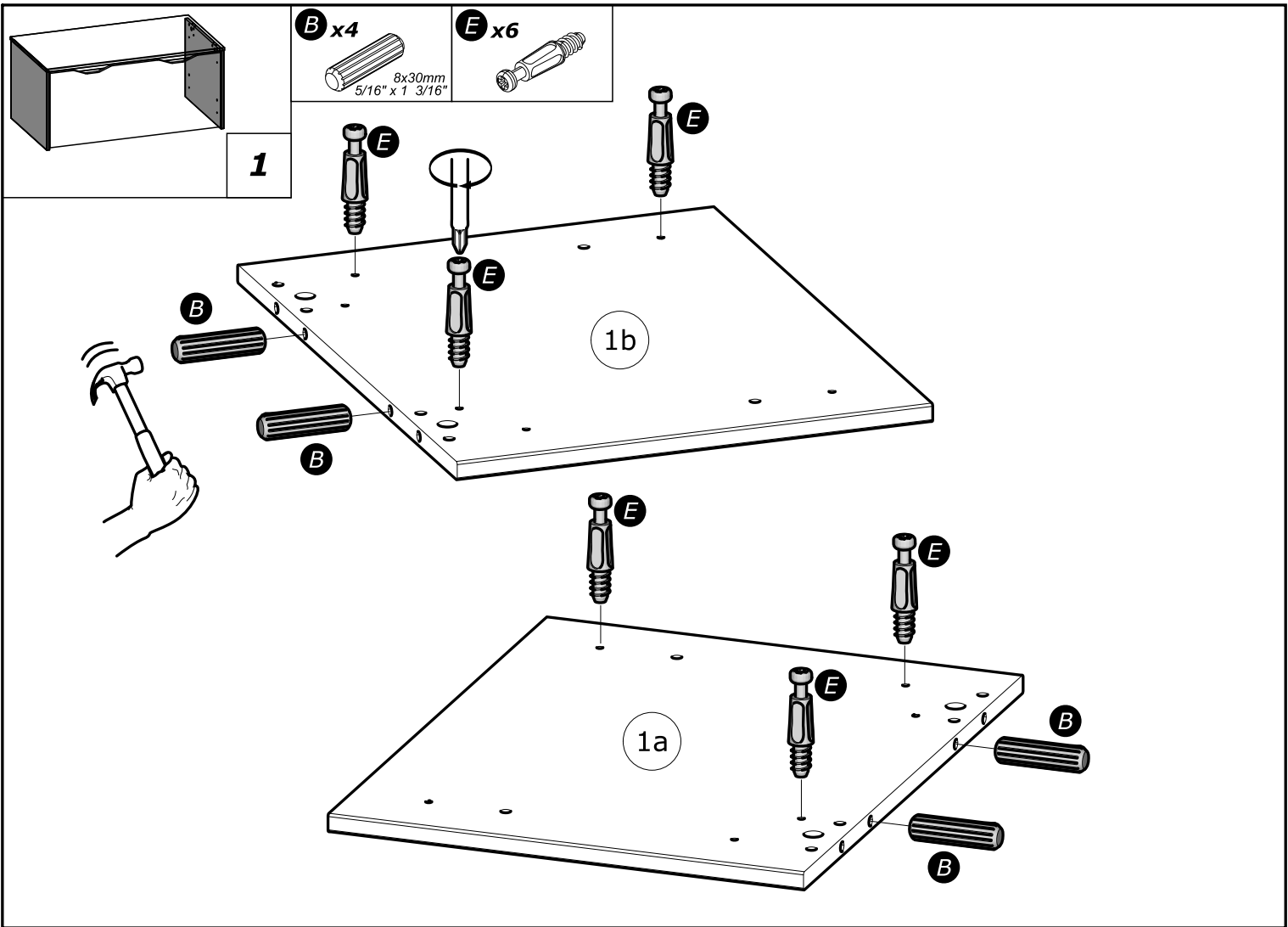

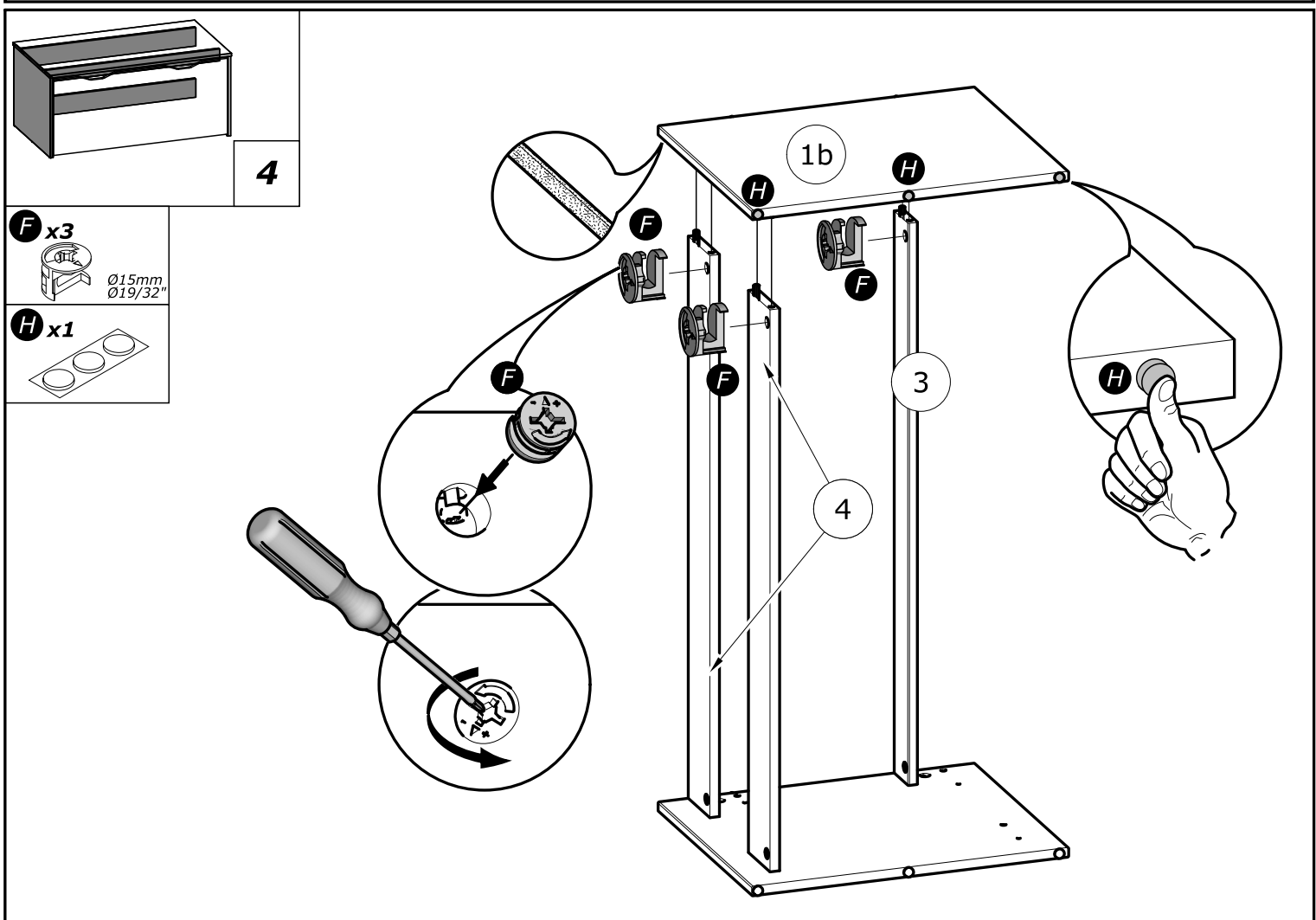
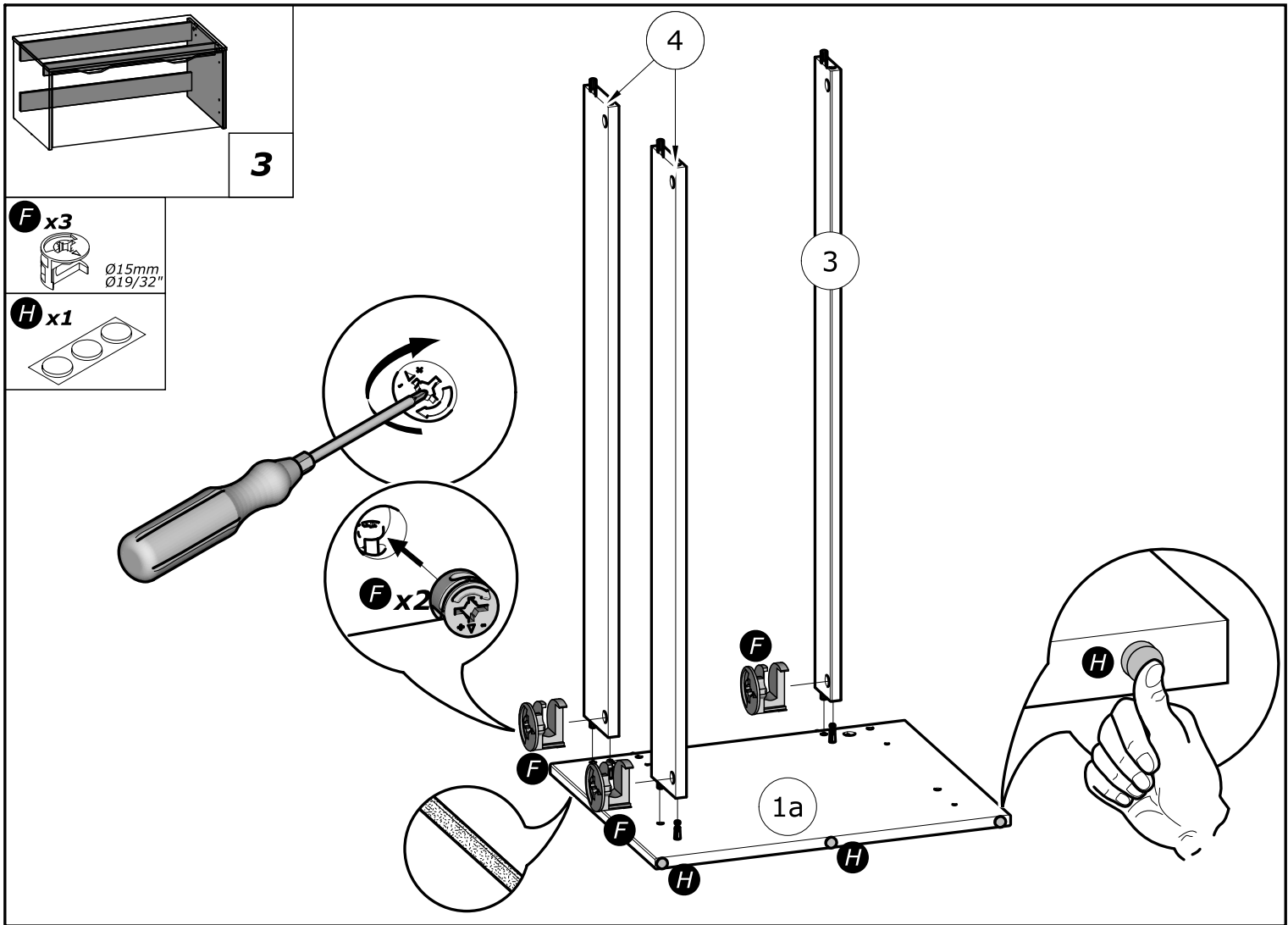

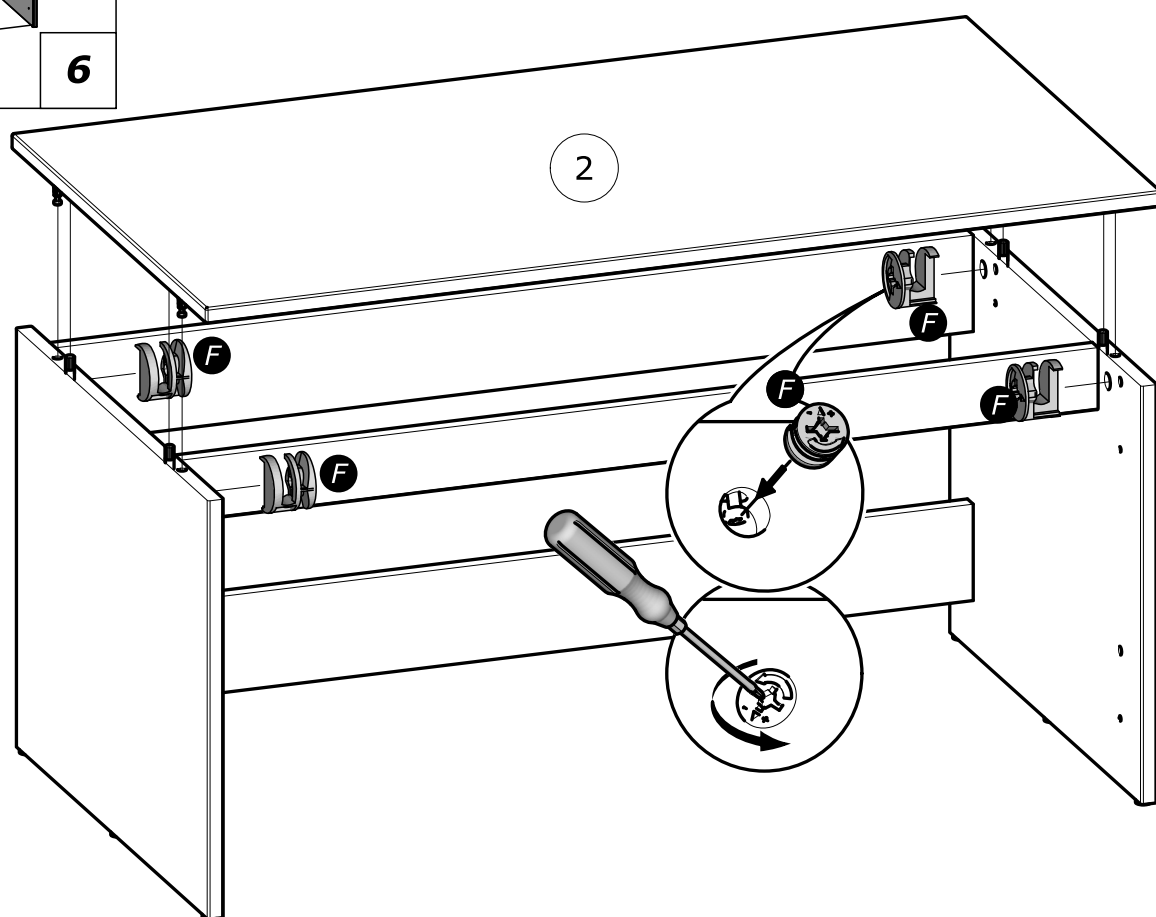
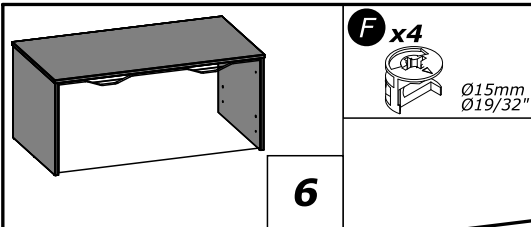
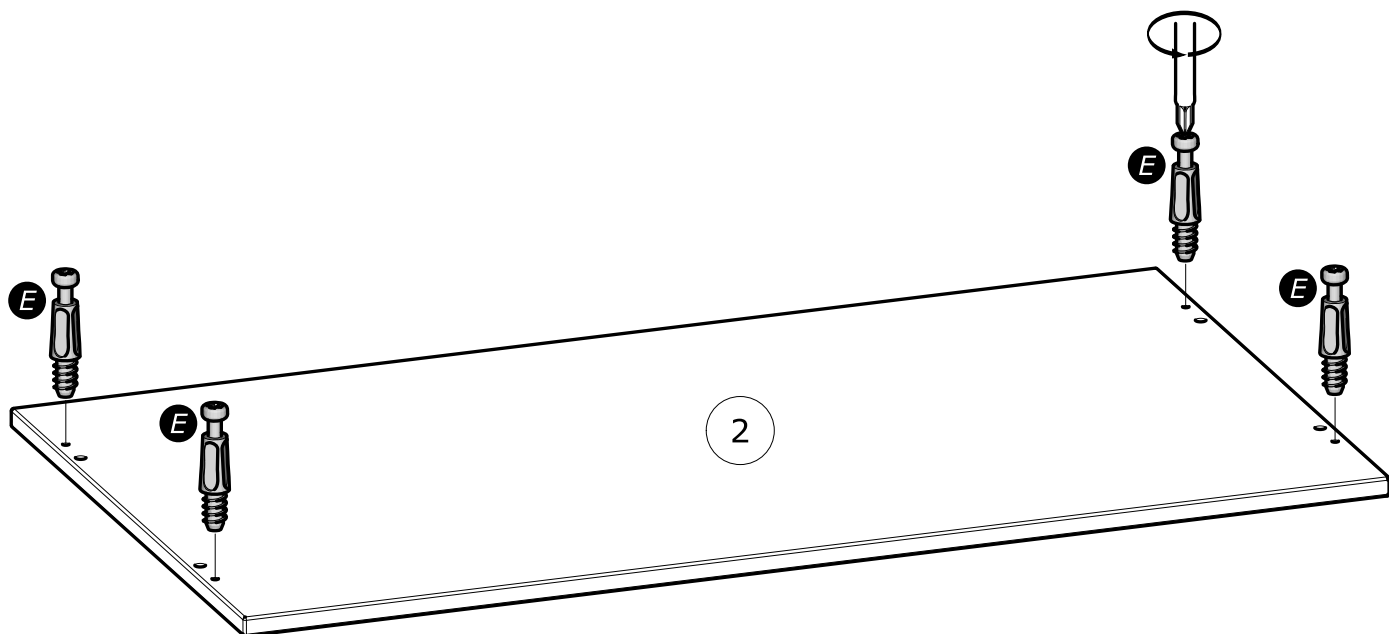
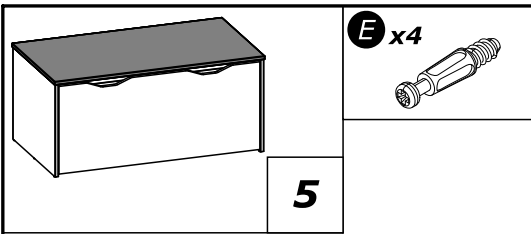

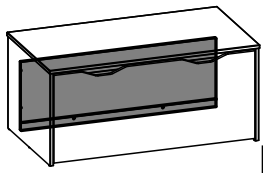

7

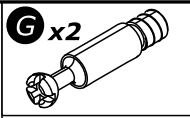

G x2

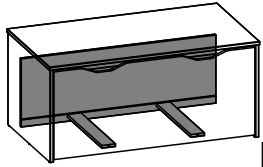
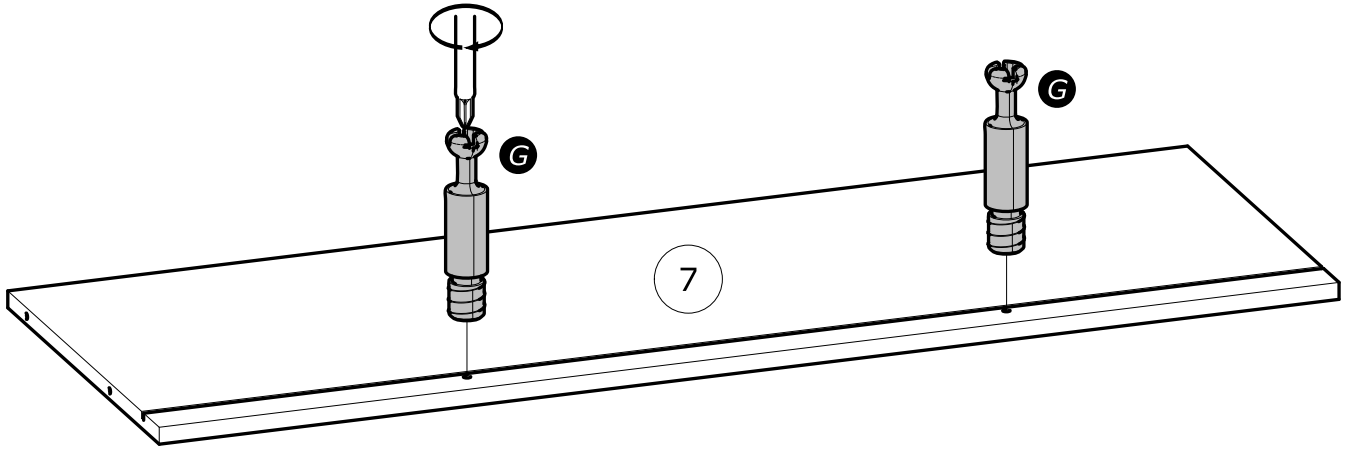

8

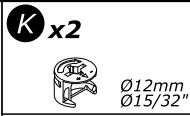

K x2

Ø12mm
Ø15/32"

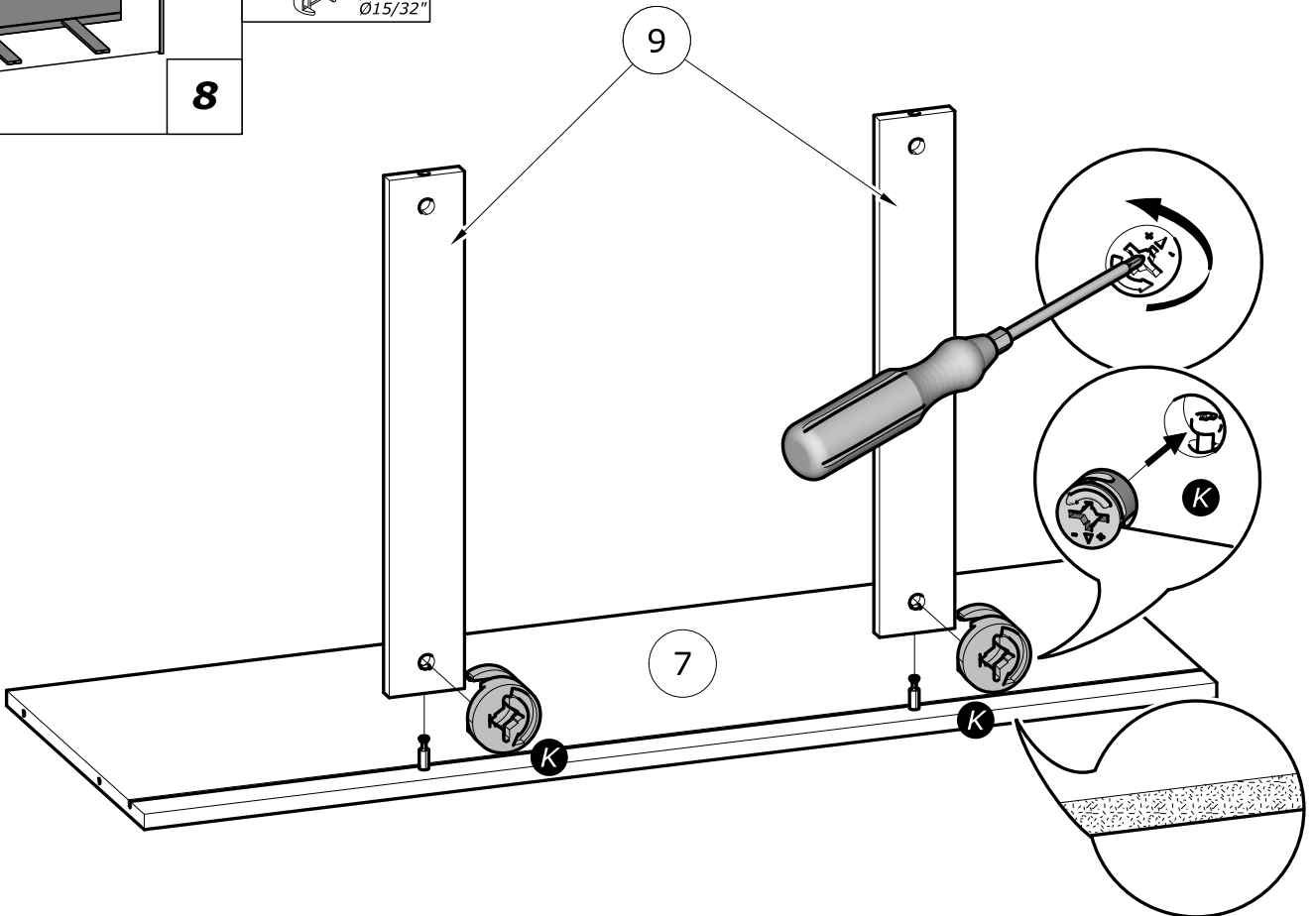

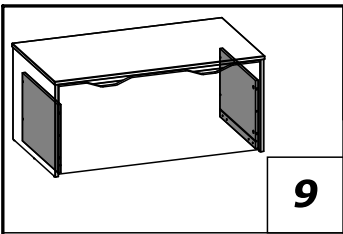

A x2
5x30mm
3/16" x 1 3/16"

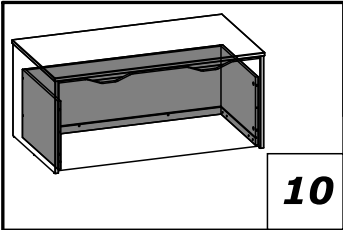
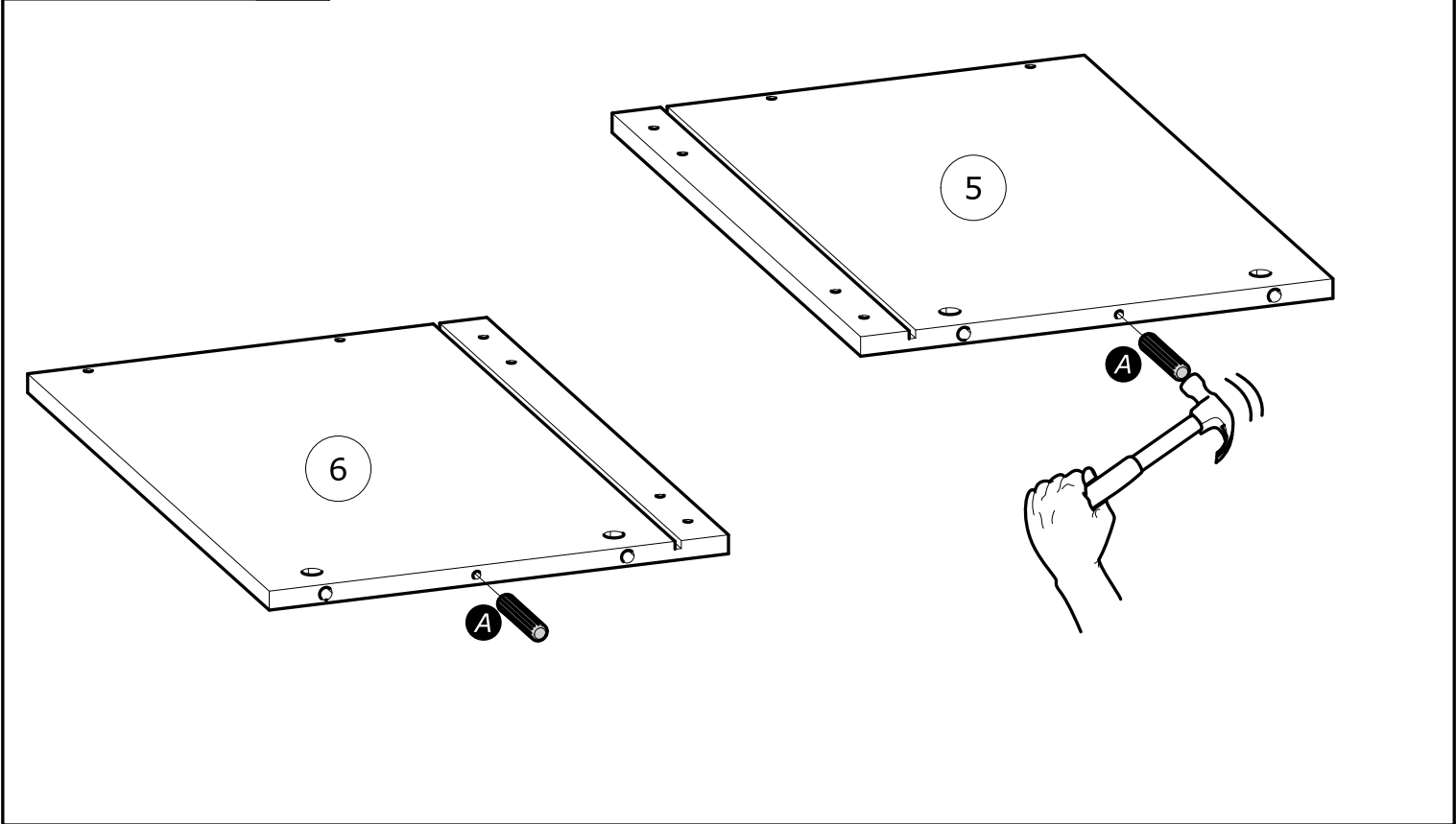

I x4
5x40mm
3/16" x 1 9/16"

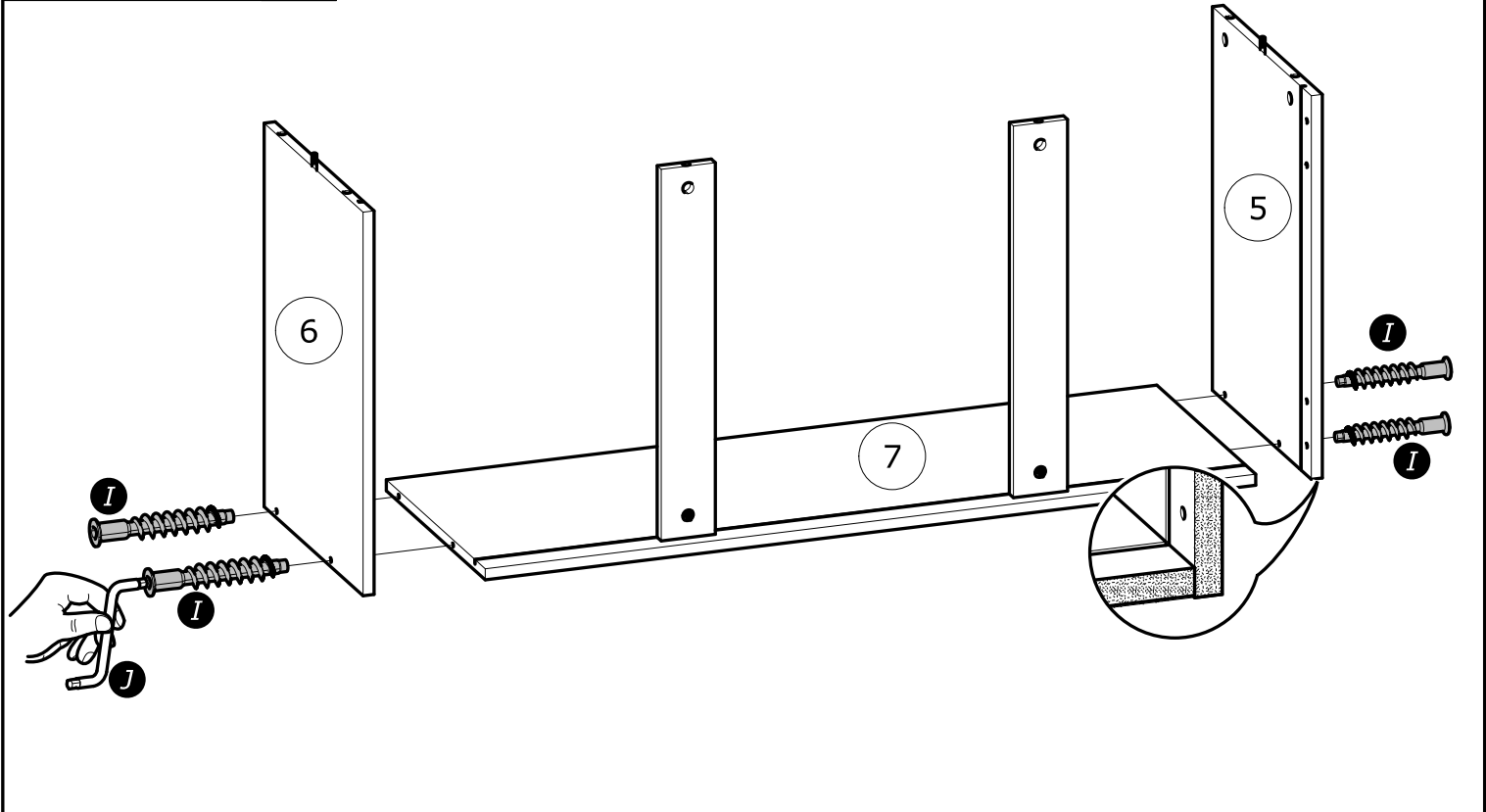
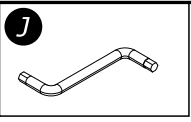

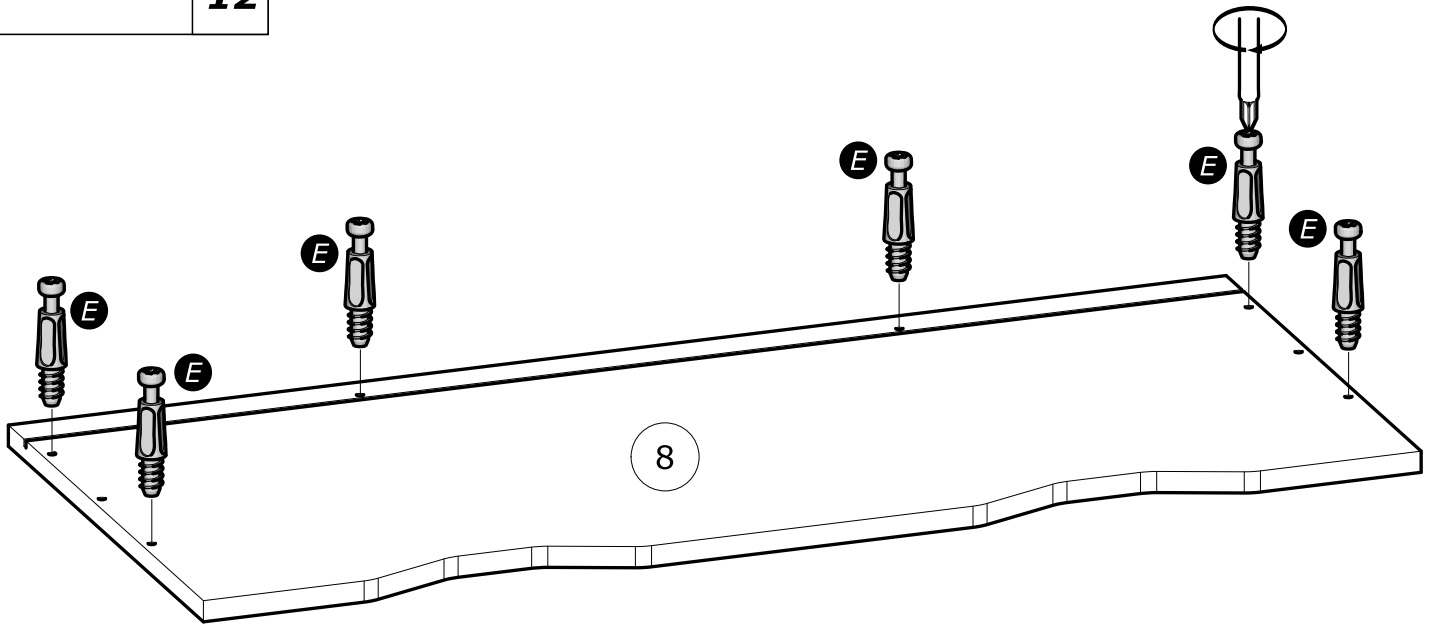
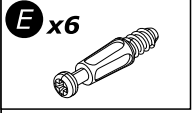
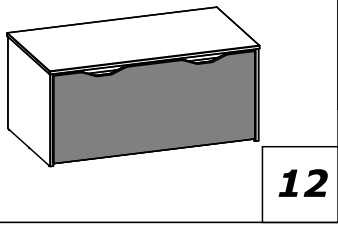
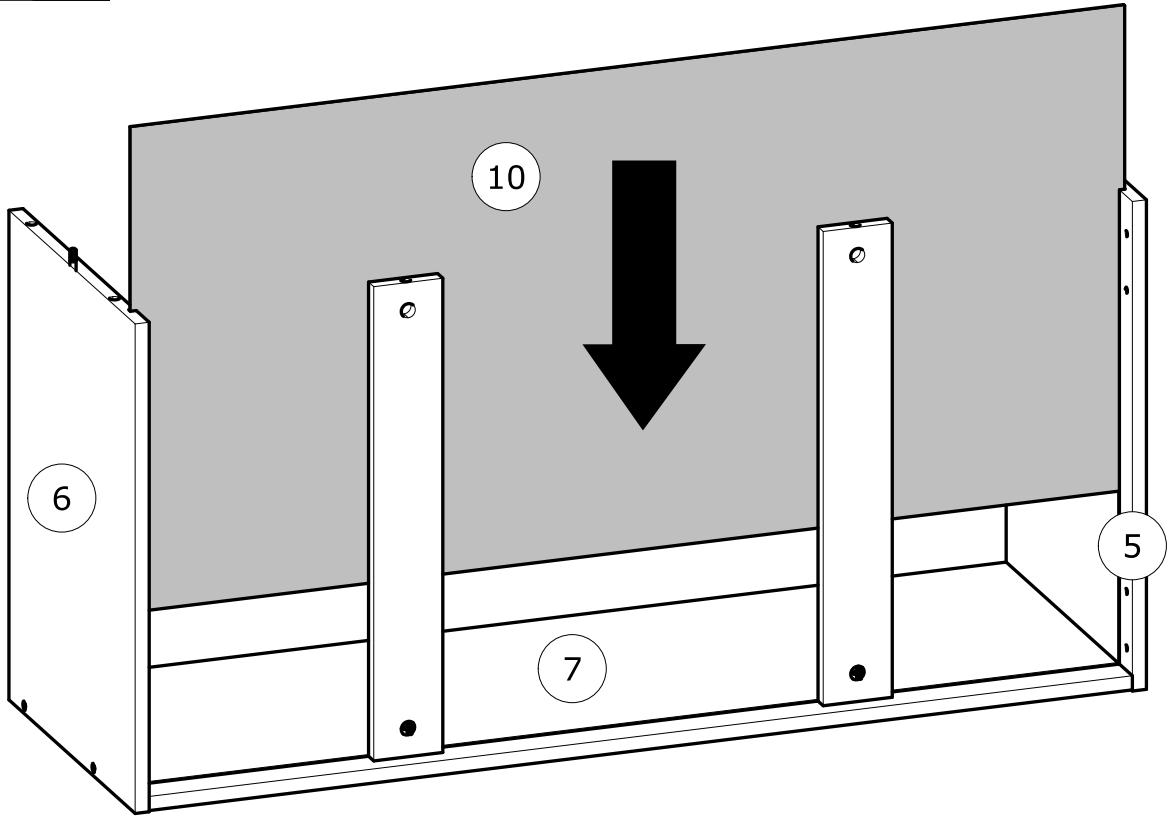
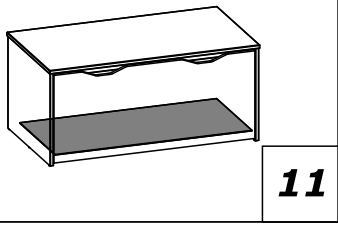

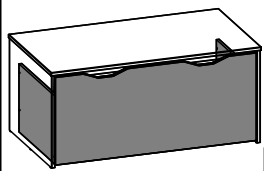

13

K x6



Ø12mm
Ø15/32"

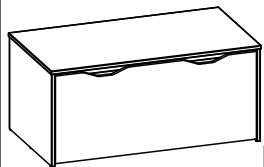
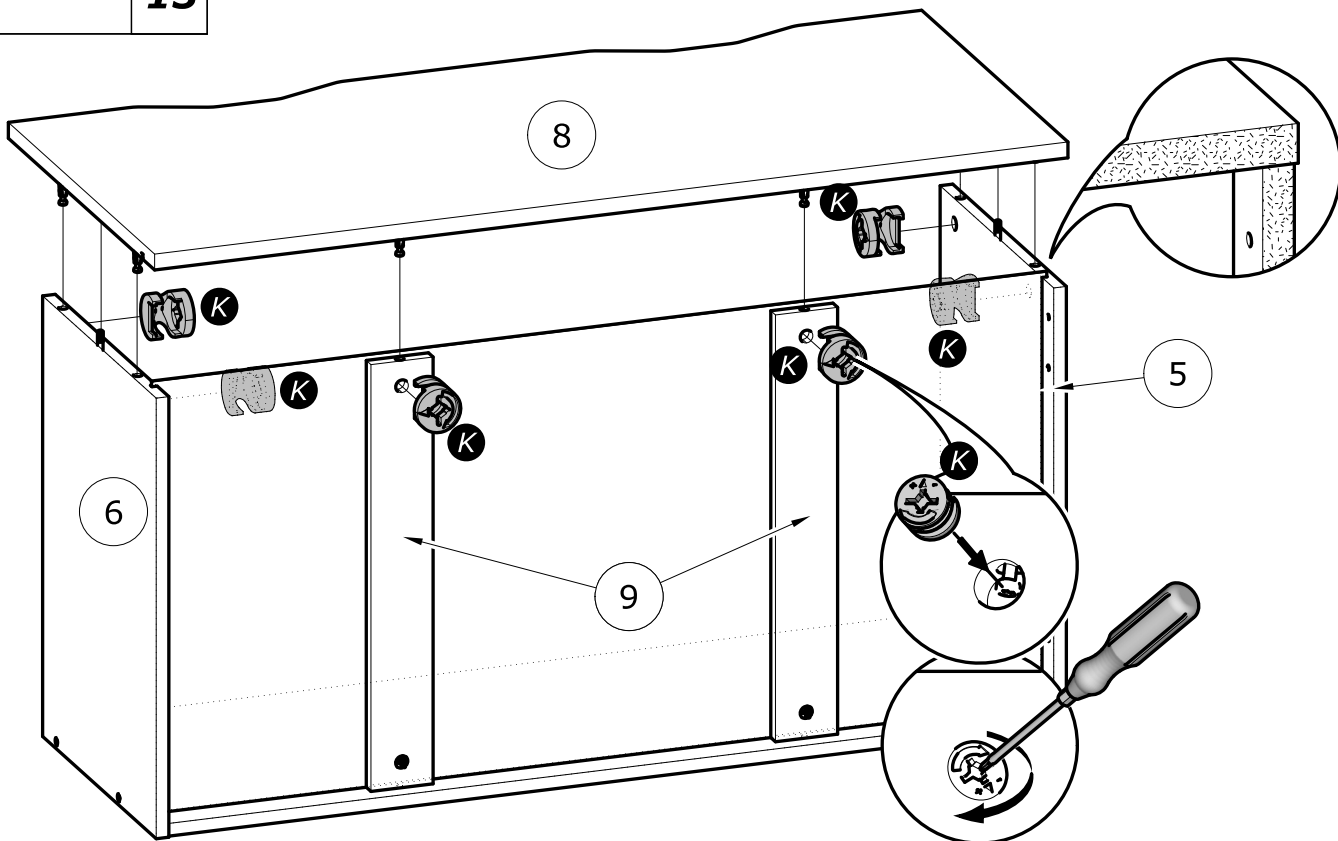

14

C x8



6.3x9mm
1/4" x 11/32"

D x4

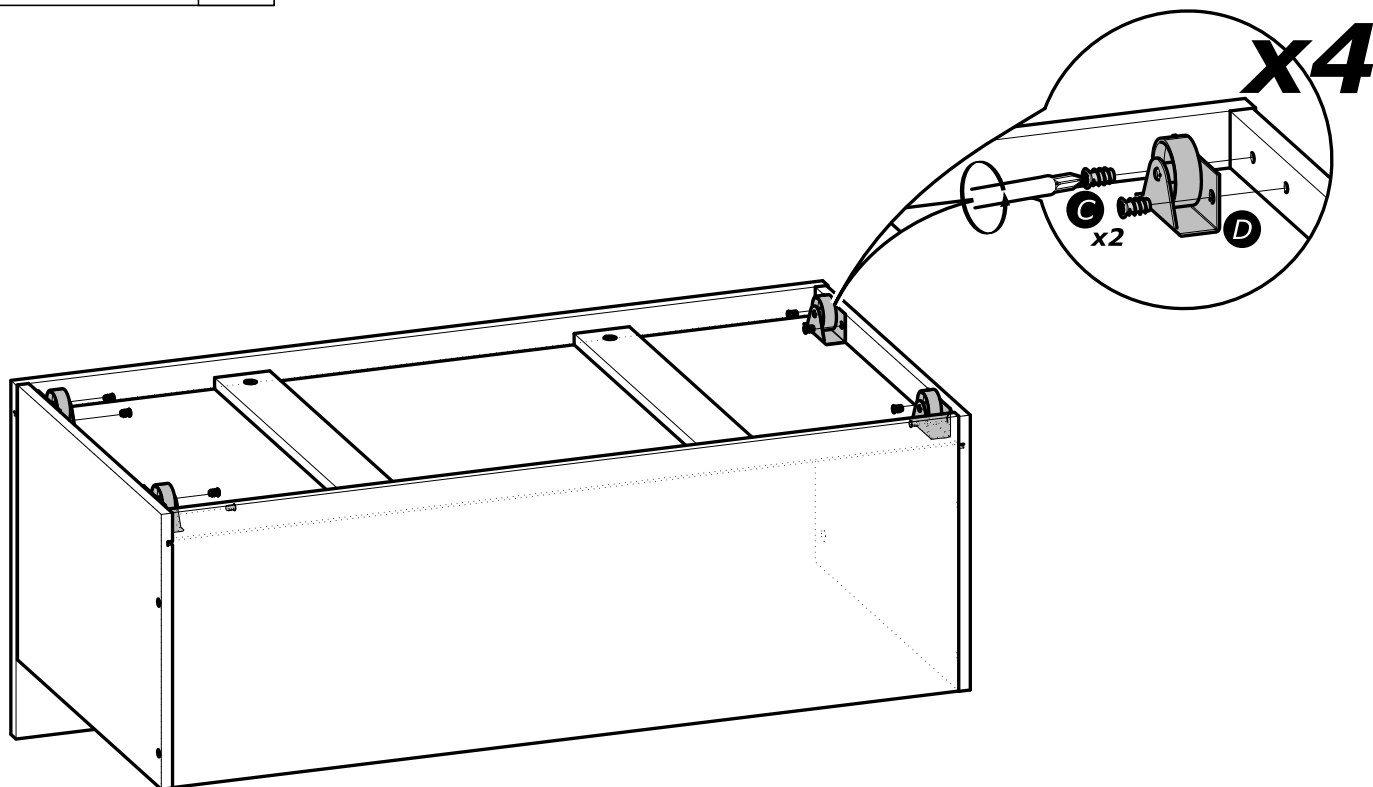
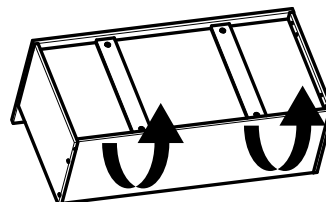
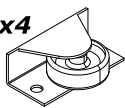

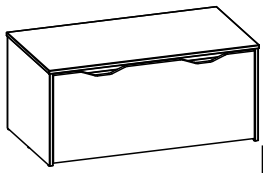

14

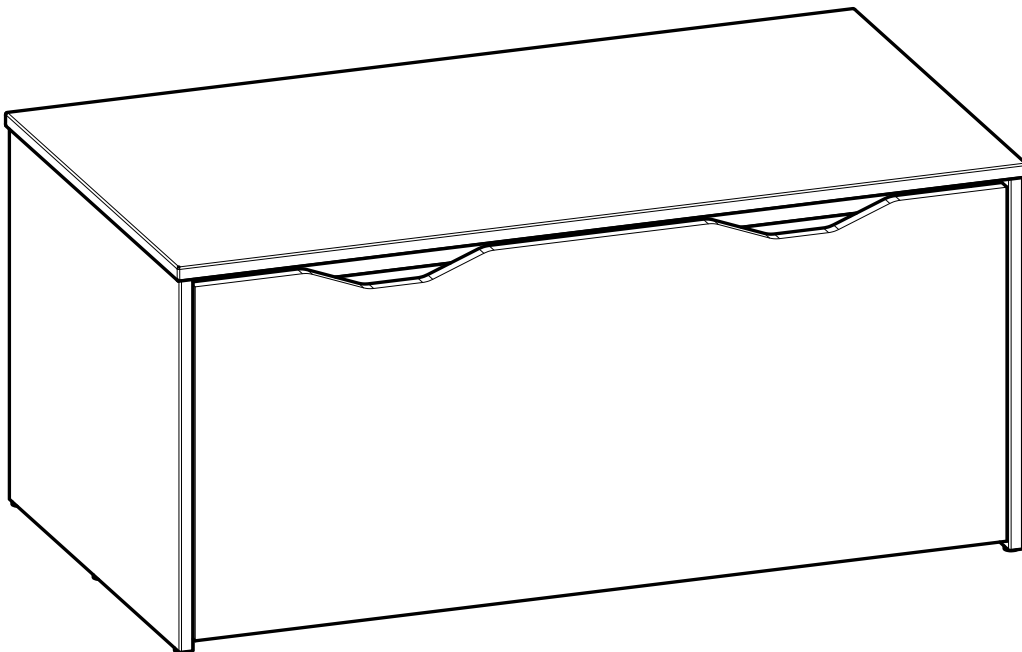
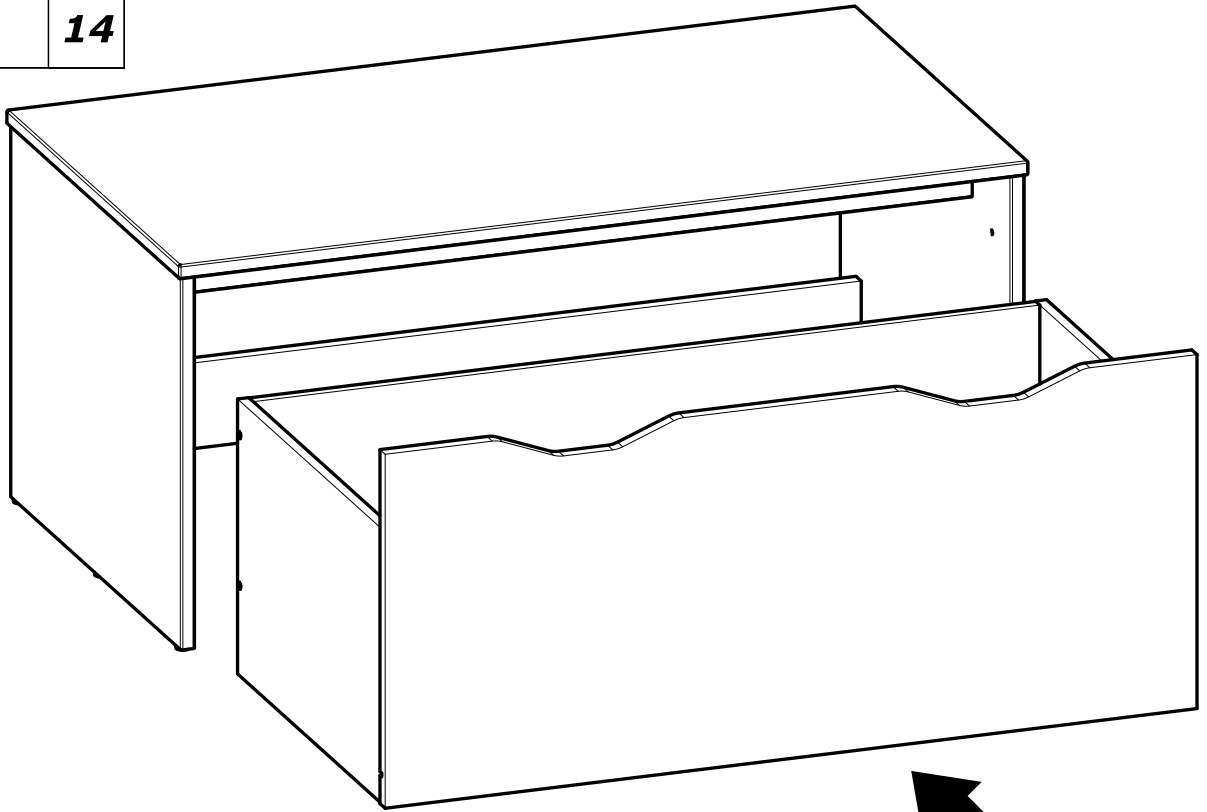

FR-Importé par / EN-Imported by / PT-Importado por / ES-Importado por / DE-Importiert von / IT-Importado da / NL-Geïmporteerd door :

UE/EU : Vertbaudet SAS-216, Rue winoc Chocqueel, 59200 Tourcoing , France

UK : Vertbaudet UK Limited - Elder house, St Georges Business Park, 207 Brooklands Road, Weybridge, Surrey KT13 0TS