

- Contrôler le contenu de votre colis avant de procéder au montage
- Ne détériorez pas l'emballage, il vous sera très utile pour protéger les éléments des coups et rayures pendant le montage
- Assemblez ensuite le meuble en suivant l'ordre défini par la numérotation
- Du fait de son confinement dans le carton après emballage, il est possible qu'au déballage et au montage votre produit dégage dans l'air des odeurs de vernis, plus ou moins prononcées. Ce dégagement est normal, il correspond à la fin de la maturation de la finition de votre produit. Afin que ces odeurs ne vous incommode pas, nous vous conseillons de disposer votre produit dans une pièce convenablement et régulièrement aérée, en ouvrant complètement les portes et en déposant les tiroirs à côté du meuble, jusqu'à disparition de ces odeurs.

- Check the contents of your parcel before assembling
- Do not throw away the packing which could be very useful to protect the components from knocks and scratches when assembling
- Next assemble the article following the order of the numbers indicated
- You may notice a smell of varnish when you unpack your item, due to its having been stored in a box since its packaging. This smell can sometimes be quite strong. This is entirely normal, and is simply the result of the final stage in the maturing of the cabinet's finish. In order to avoid any inconvenience that may be caused by such odours, we recommend that you place the item in a well ventilated room, opening all doors, and removing the drawers from the cabinet, until any such odours have dissipated.

- Confira o conteúdo da sua encomenda antes de iniciar a montagem
- Não danifique a embalagem, poderá ser-lhe útil para proteger os elementos de golpes e riscos durante a montagem
- Proceda à montagem do móvel seguindo a ordem definida pela numeração
- Devido ao seu encerramento na caixa de cartão após o acondicionamento, é possível que, no momento da desembalagem e montagem do produto, este lance para o ar um cheiro a verniz, mais ou menos intenso. Esta é uma situação normal, que corresponde ao final da maturação do acabamento do seu produto. Para que este cheiro não o incomode, aconselhamos-lhe a colocar o produto num compartimento adequado e regularmente arejado, deixando as portas totalmente abertas e colocando as gavetas ao lado do móvel, até que o referido cheiro desapareça.

- Controlar el contenido de su embalaje antes de proceder al montaje
- No deteriorar el paquete, que le será muy útil para proteger los elementos de golpes y rozaduras durante el montaje.
- Acoplar de seguida el mueble, siguiendo la orden definida por la numeración
- Dado que el mueble ha permanecido encerrado en la caja de cartón desde el momento de su acondicionamiento, es posible que al desembalarlo desprenda a la atmósfera un olor a barniz más o menos pronunciado. Este olor es normal y corresponde a la etapa final de la maduración del acabado del producto que adquirió. Con el fin de evitar que esos olores sean para usted una incomodidad, le aconsejamos dejar el producto en un lugar adecuado y regularmente aireado; abrir por completo las puertas, retirar los cajones y dejarlos aireándose junto al mueble, hasta que tales olores hayan desaparecido.

- Vor Montage den Inhalt Ihres Päckchens kontrollieren
- Die Verpackung nicht zerstören, sie wird Ihnen nützlich sein, um die Teile bei der Montage vor Stößen und Kratzern zu schützen.
- Das Möbel dann in der Reihenfolge der Nummerierung zusammenbauen
- Da das Möbelstück eine gewisse Zeit lang eng verpackt war, ist nicht auszuschließen, dass sich beim Auspacken und der Montage ein mehr oder minder starker Lackgeruch entwickelt. Diese Geruchsentwicklung nach der Endbearbeitung ist durchaus normal. Damit der Lackgeruch Sie nicht stört, empfehlen wir Ihnen, Ihren Einrichtungsgegenstand in einen gut und regelmäßig gelüfteten Raum zu stellen, die Schubladen herauszunehmen und die Türen ganz zu öffnen, bis sich der Lackgeruch vollständig verflüchtigt hat.

- Verificare il contenuto della confezione prima del montaggio
- Non eliminare l'imballo che potrà essere utilizzato per proteggere il prodotto dai danni durante il montaggio
- Montare l'articolo seguendo l'ordine di numerazione
- Per il fatto di essere rimasto chiuso nel cartone dopo l'imballaggio, è possibile che il mobile una volta liberato dal cartone e durante il montaggio sprigioni nell'aria odori di vernice più o meno forti. E' un fatto assolutamente normale, e indica la fine della maturazione della finitura del prodotto. Affinché questi odori non Le creino fastidio, raccomandiamo di collocare il prodotto in un locale adeguatamente e regolarmente aerato, aprendo completamente le porte e depositando i cassetti accanto al mobile fino alla scomparsa degli odori.

- De inhoud van uw pakket controleren alvorens met de montage te beginnen
- De verpakking niet beschadigen, deze kan heel handig zijn om de onderdelen te beschermen tegen schokken en krassen tijdens de montage
- Zet vervolgens het meubel in elkaar in de volgorde die is bepaald in de nummering
- Het is mogelijk dat zich bij het uitpakken en in elkaar zetten van uw product een min of meer uitgesproken laklucht verspreidt. Dit komt omdat het product na het inpakken in de doos heeft gezeten. Het is normaal dat dit gebeurt, het hoort bij de uiteindelijke afwerking van uw product. Om te voorkomen dat u last heeft van deze lucht, raden we u aan om uw product in een voldoende en regelmatig geventileerde ruimte neer te zetten. Doe daarbij de deurtjes helemaal open en zet de laden naast het meubel neer totdat deze lucht is verdwenen.

FR - Notice de montage / EN - Assembly instructions / PT - Instruções de montagem /  
ES - Prospecto de montaje / DE - Montageanleitung / IT - Istruzioni di montaggio /  
NL - Montagehandleiding

## **FR – IMPORTANT! CONSERVER POUR CONSULTATION ULTERIEURE: LIRE ATTENTIVEMENT**

- A monter par un adulte. Un adulte doit vérifier le bon assemblage avant l'emploi
- ATTENTION! tenir les vis et petits éléments et sachets hors de portée des enfants
- Bien identifier les éléments avant de commencer le montage
- Ne pas utiliser votre article lorsque l'un de ses éléments est cassé ou manquant
- En cas de problème contactez notre service après-vente
- Toujours suivre les instructions du fabricant
- Ne pas monter sur le produit
- Entretien: nettoyer avec un chiffon doux et sec. En cas de taches plus grosses, frottez soigneusement avec une éponge légèrement humide et non abrasive
- ATTENTION! Ne convient pas aux enfants de moins de 3 ans. Petits éléments. Danger d'étouffement.

## **EN – IMPORTANT! KEEP FOR FUTURE REFERENCE: READ CAREFULLY**

- To be assembled by an adult. Assembly must be checked by an adult before use
- WARNING! keep all screws, small parts and plastic bags out of the reach of children
- Properly identify all parts before assembling
- Never use your item if any of its parts are broken or missing
- Should any problems arise, please contact our After Sales Service
- Manufacturer's instructions shall be followed at all times
- Do not climb on the product
- Care: clean with a soft, dry cloth. In case of larger stains, carefully rub with a slightly damp, non-abrasive sponge
- WARNING! Not suitable for children under 3 years. Small parts. Choking hazard.

## **PT – IMPORTANTE! GUARDE PARA CONSULTA POSTERIOR: LER ESTAS INSTRUÇÕES CUIDADOSAMENTE**

- A ser montado por um adulto. Um adulto deve verificar a boa montagem antes da utilização

- **ATENÇÃO!** mantenha os parafusos, acessórios pequenos e saco de plástico fora do alcance das crianças
- Identifique bem os acessórios antes de começar a montagem
- Não utilizar o artigo se um dos elementos está em falta ou danificado
- Para qualquer esclarecimento, contacte os nossos serviços através do telefone
- As instruções do fabricante devem ser sempre cumpridas
- Não suba para cima do produto
- Manutenção: limpe com um pano macio e seco. Em caso de manchas maiores, esfregue cuidadosamente com uma esponja ligeiramente húmida e não abrasiva
- **ATENÇÃO!** Não destinado a crianças menores de três anos. Peças pequenas. Risco de sufocamento.

## **ES – IMPORTANTE! CONSERVAR PARA FUTURAS CONSULTAS: LEER DETENIDAMENTE**

- A montar por un adulto. Un adulto debe comprobar el buen montaje antes de la utilización
- ¡ADVERTENCIA! mantener los tornillos, los pequeños elementos y bolsitas fuera del alcance de los niños
- Identificar debidamente los elementos antes de empezar el montaje
- No utilizar este artículo si uno de los elementos falta o esta roto
- Si tiene problemas, contactar nuestro servicio postventa
- Deben seguirse siempre las instrucciones del fabricante
- No subir sobre el producto
- Cuidados: limpiar con un paño suave y seco. En caso de manchas grandes, frotar con cuidado utilizando una esponja húmeda no abrasiva
- ¡ADVERTENCIA! No conveniente para niños menores de 3 años. Piezas pequeñas. Riesgo de asfixia.

## **DE – WICHTIG! FÜR SPÄTERE BEZUGNAHME AUFBEWAHREN: SORGFÄLTIG LESEN**

- Von einem Erwachsenen zu montieren. Die korrekte Montage muss vor Gebrauch von einem Erwachsenen geprüft werden
- **ACHTUNG!** die Schrauben und kleinen Teile ausserhalb der Reichweite von Kindern lagern
- Vor Montagebeginn alle Teile identifizieren
- Ihren Artikel nicht benutzen, wenn eines seiner Bestandteile beschädigt ist oder fehlt
- Im Problemfall Ihren Kundendienst anrufen
- Stets die Herstelleranweisungen beachten
- Nicht auf das Produkt steigen
- **Wartung:** Mit einem weichen, trockenen Tuch reinigen. Bei größeren Flecken vorsichtig mit einem leicht feuchten, nicht scheuernden Schwamm abreiben
- **ACHTUNG!** Nicht für Kinder unter 3 Jahren. Kleine Teile. Erstickungsgefahr.

# **IT - IMPORTANTE! CONSERVARE QUESTE INFORMAZIONI PER ULTERIORI CONSULTAZIONI: LEGGI ATTENTAMENTE**





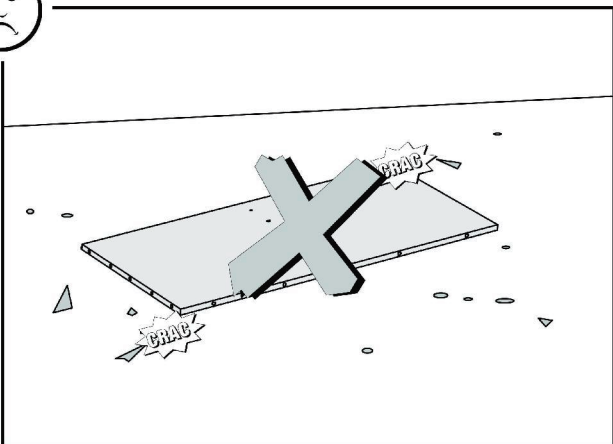
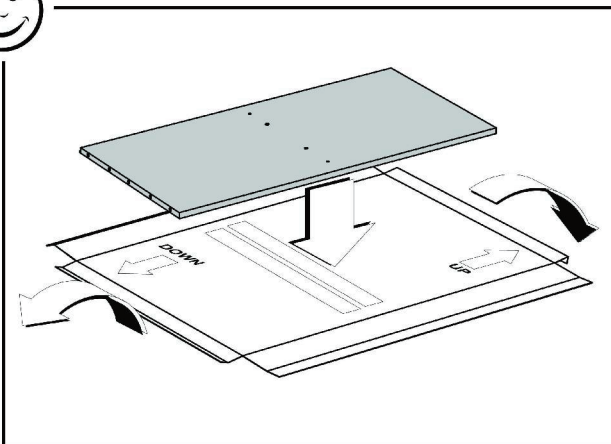
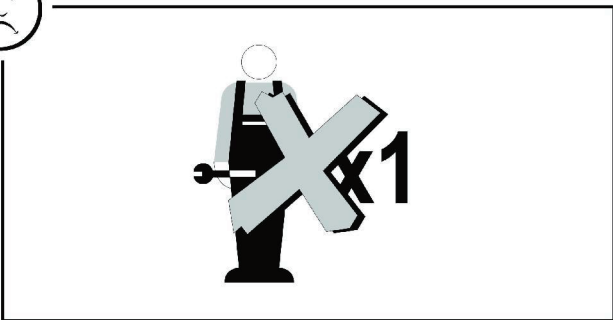
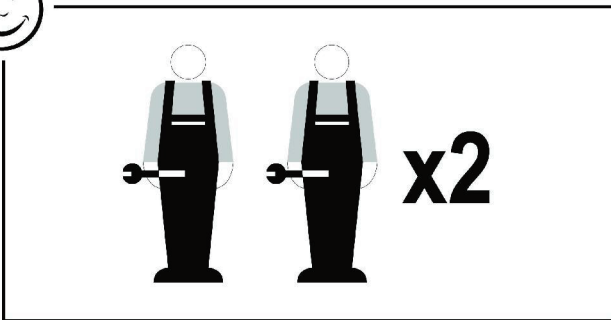
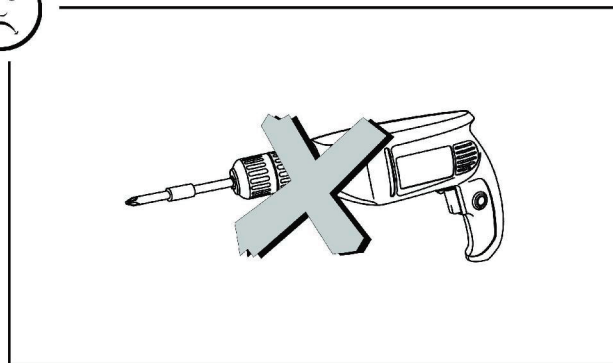
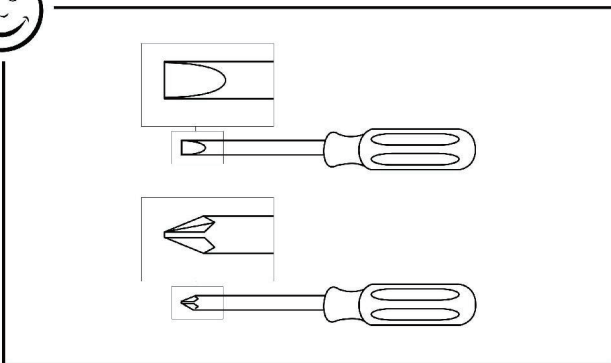
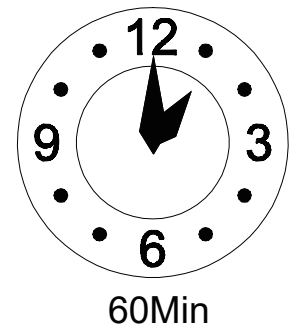
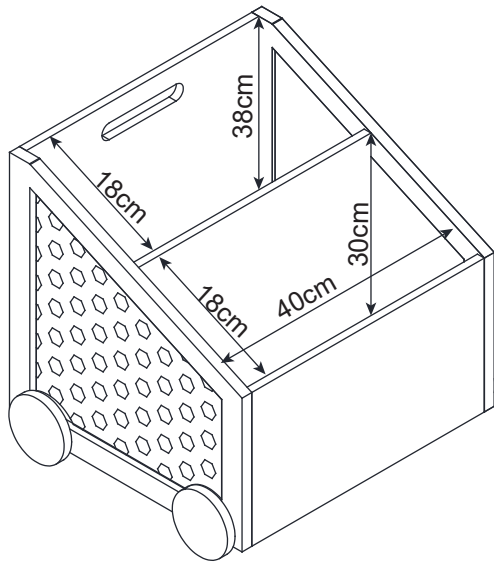

- Il montaggio deve essere eseguito da un adulto. Un adulto dovrà verificare il corretto montaggio prima dell'uso
- **ATTENZIONE!** tenere le viti ed i componenti di piccole dimensioni lontano dalla portata dei bambini
- Controllare i pezzi prima del montaggio
- L'articolo non deve essere utilizzato in caso di elementi mancanti o danneggiati
- In caso di necessità contattare il nostro servizio post-vendita
- Seguire sempre le istruzioni del costruttore
- Non salire sul prodotto
- Manutenzione: pulire con un panno morbido e asciutto. Per le macchine più grandi, strofinare accuratamente con una spugna leggermente umida e non abrasiva
- **ATTENZIONE!** Non adatto a bambini di età inferiore a 3 anni. Piccoli pezzi. Rischio di soffocamento.

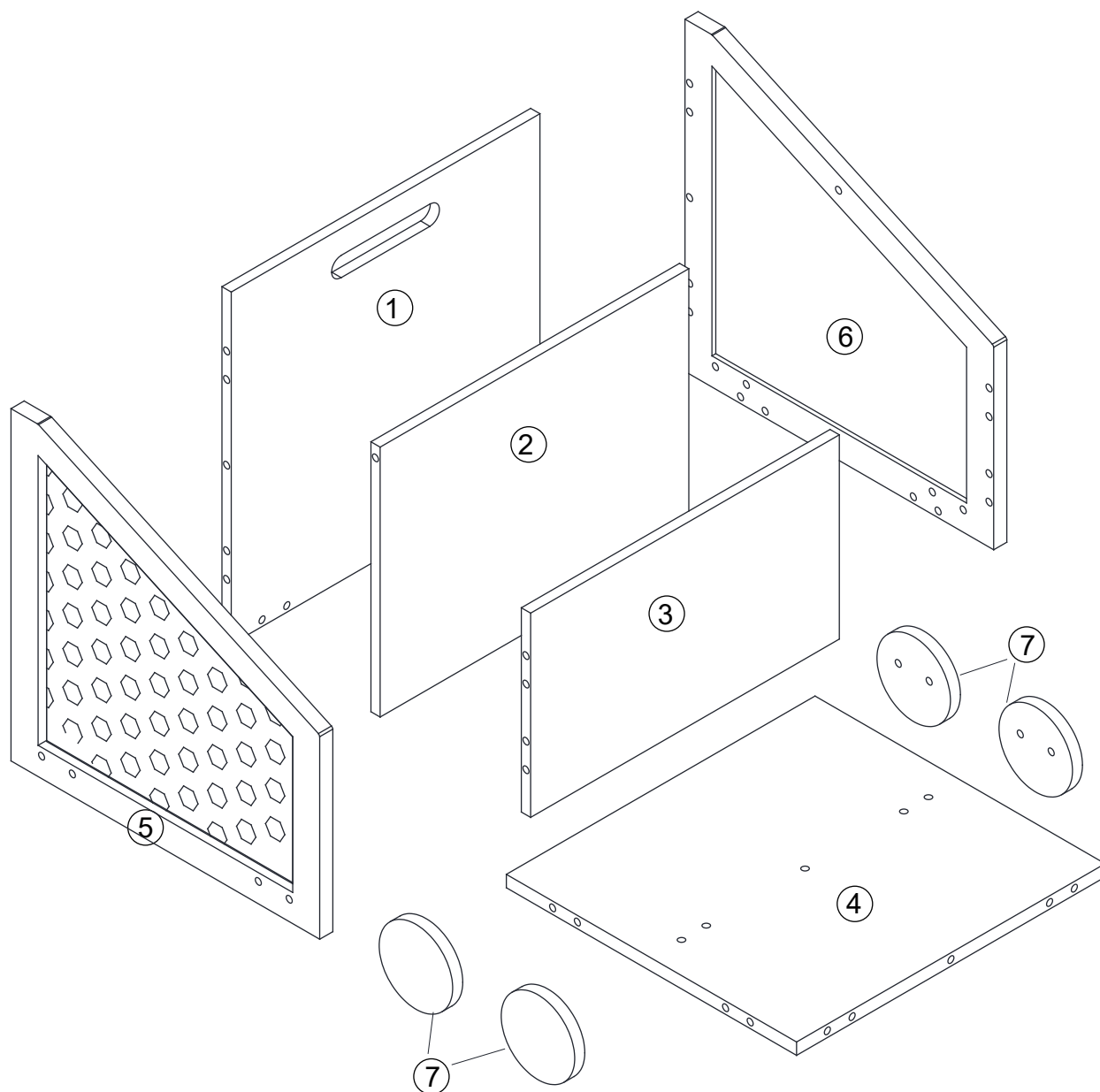
# **NL - BELANGRIJK! BEWAAR VOOR LATERE RAADPLEGING: LEES AANDACHTIG**

- Moet door een volwassene worden gemonteerd. Voor gebruik moet een volwassene controleren dat het product goed in elkaar is gezet
- **WAARSCHUWING!** schroeven en kleine elementen en zakjes buiten bereik van kinderen houden
- De elementen goed identificeren alvorens met de montage te beginnen
- Uw artikel niet gebruiken wanneer een van de onderdelen kapot is of ontbreekt
- Neem bij problemen contact op met onze klantenservice
- Volg altijd de instructies van de fabrikant
- Niet op het product klimmen
- Onderhoud: maak schoon met een zachte en droge doek. In geval van grotere vlekken, veeg voorzichtig schoon met een licht bevochtigde en niet-schurende spons
- **WAARSCHUWING!** Is niet geschikt voor kinderen van jonger dan 3 jaar. Kleine onderdelen. Verstikkingsgevaar.

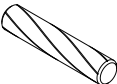

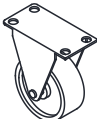

 A x 20	 ø15x10mm B x 20	 ø6x30mm C x 20	 4x35mm D x 3	 ø4x10mm E x 16	 4x18mm F x 8	 G x 4
---	---	--	--	---	--	--

# 1

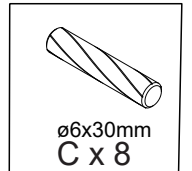
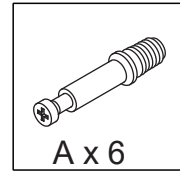
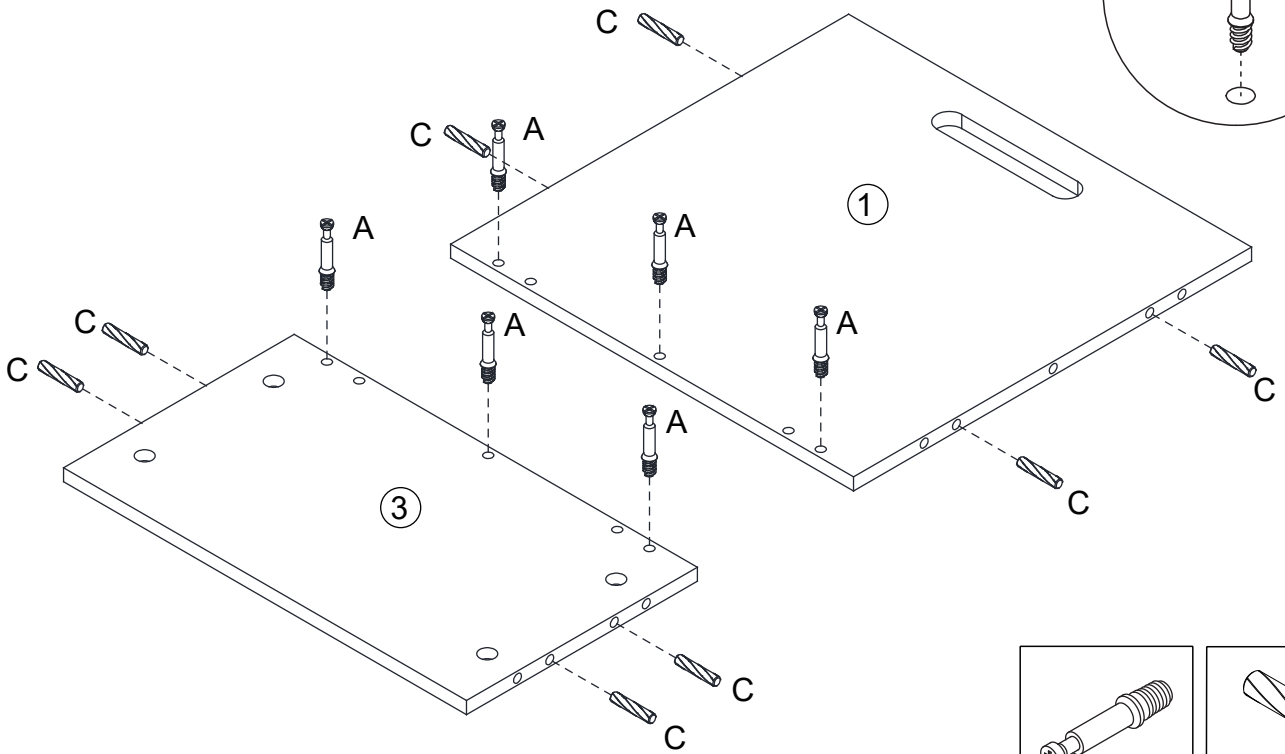

# 2

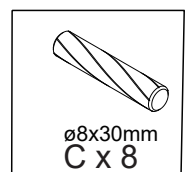
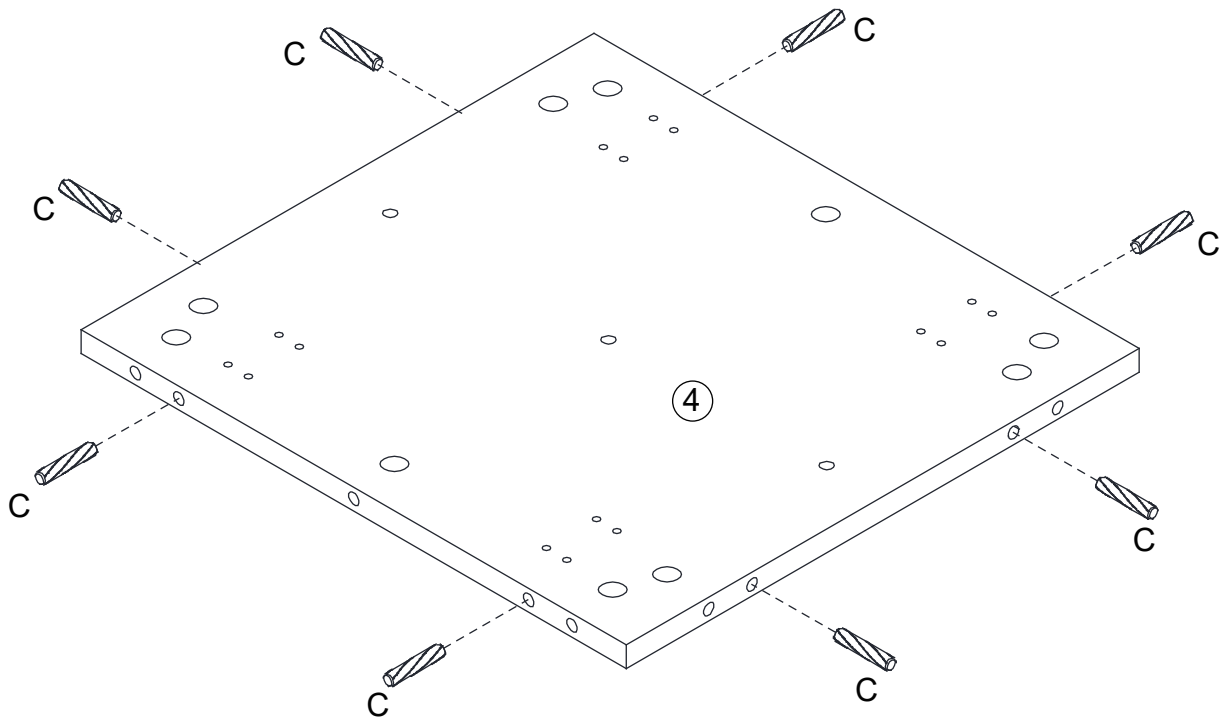

# 3

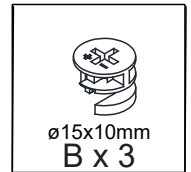
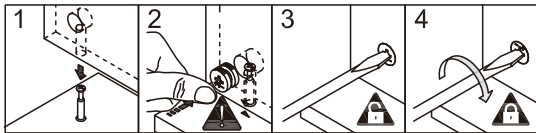
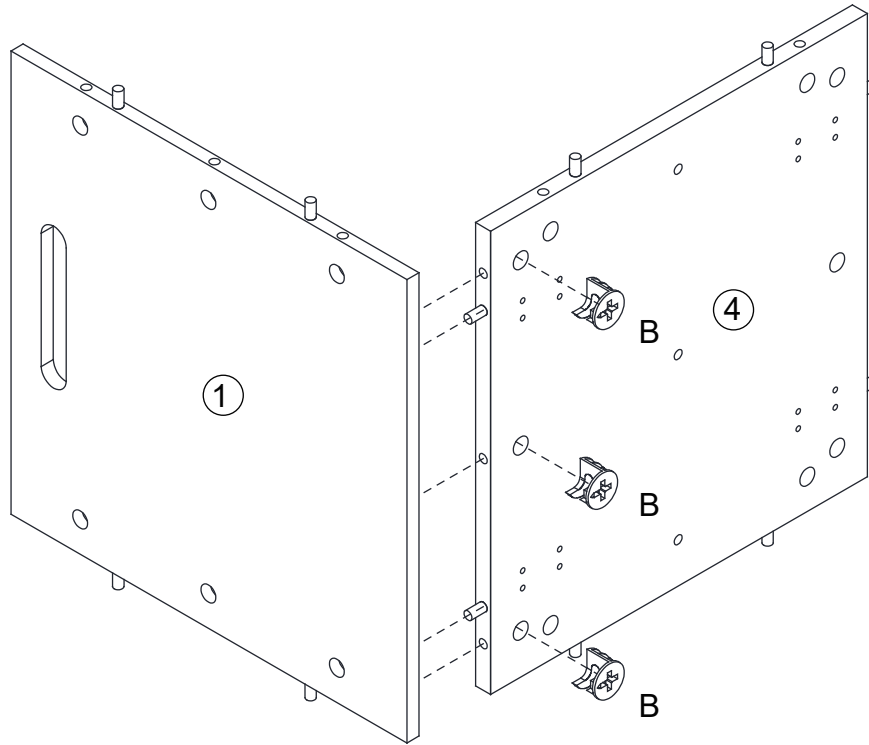

# 4

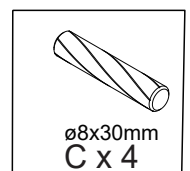
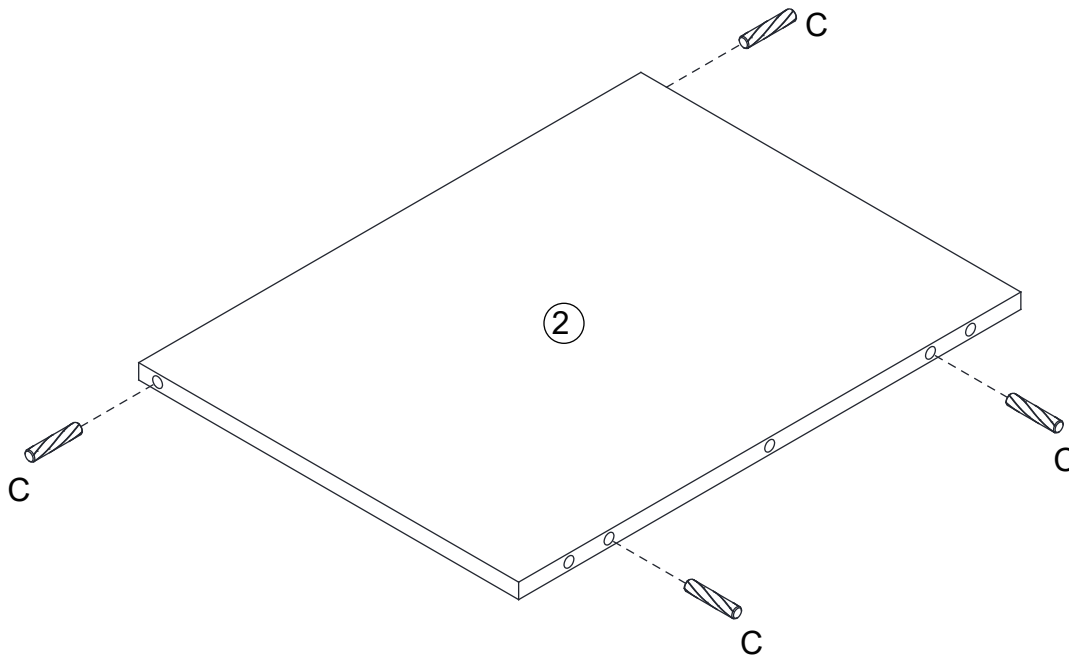



5

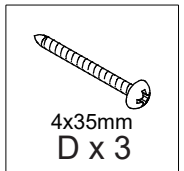
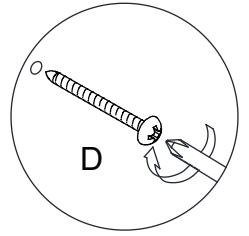
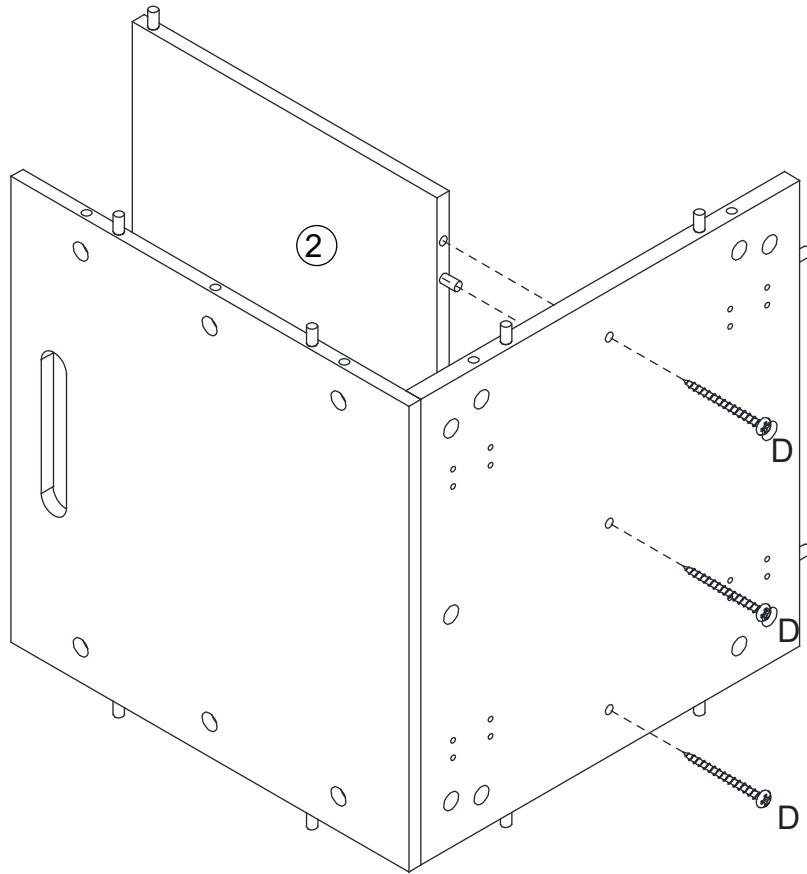

6

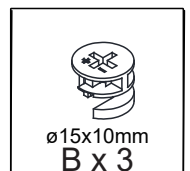
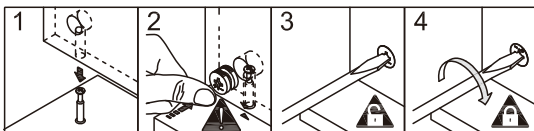
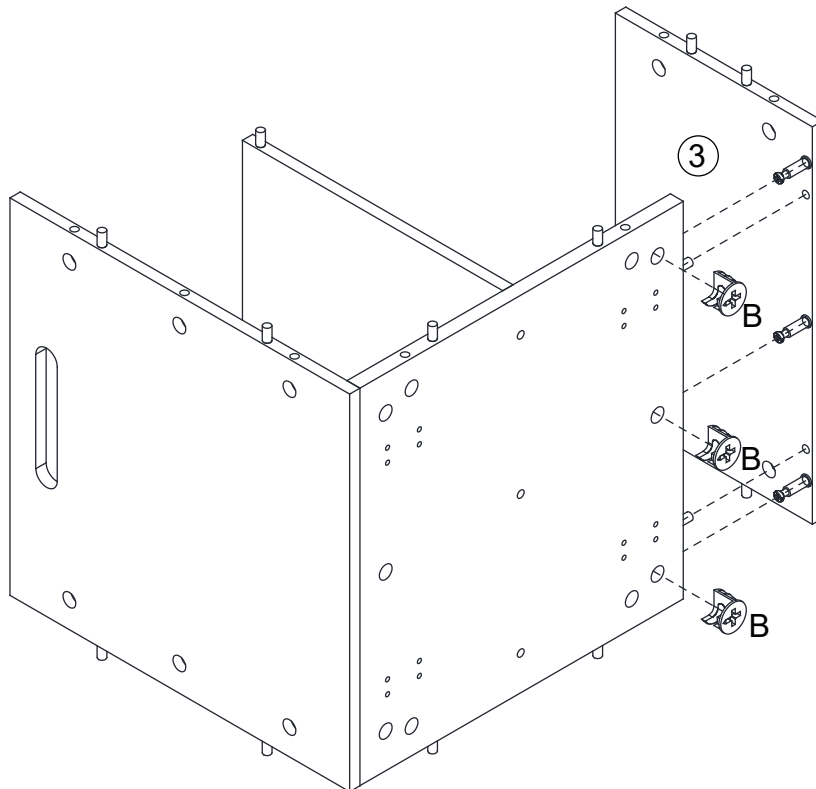

7

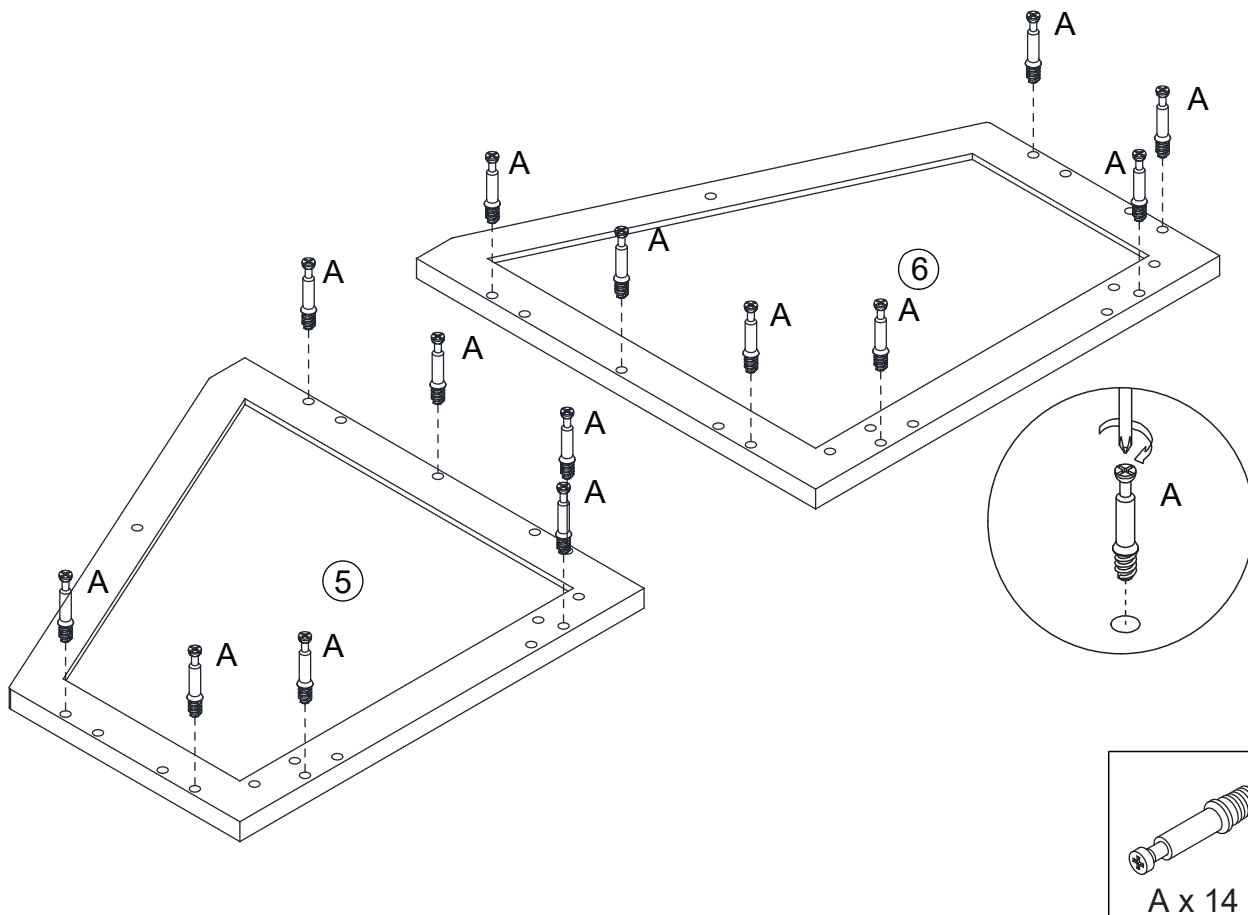

8

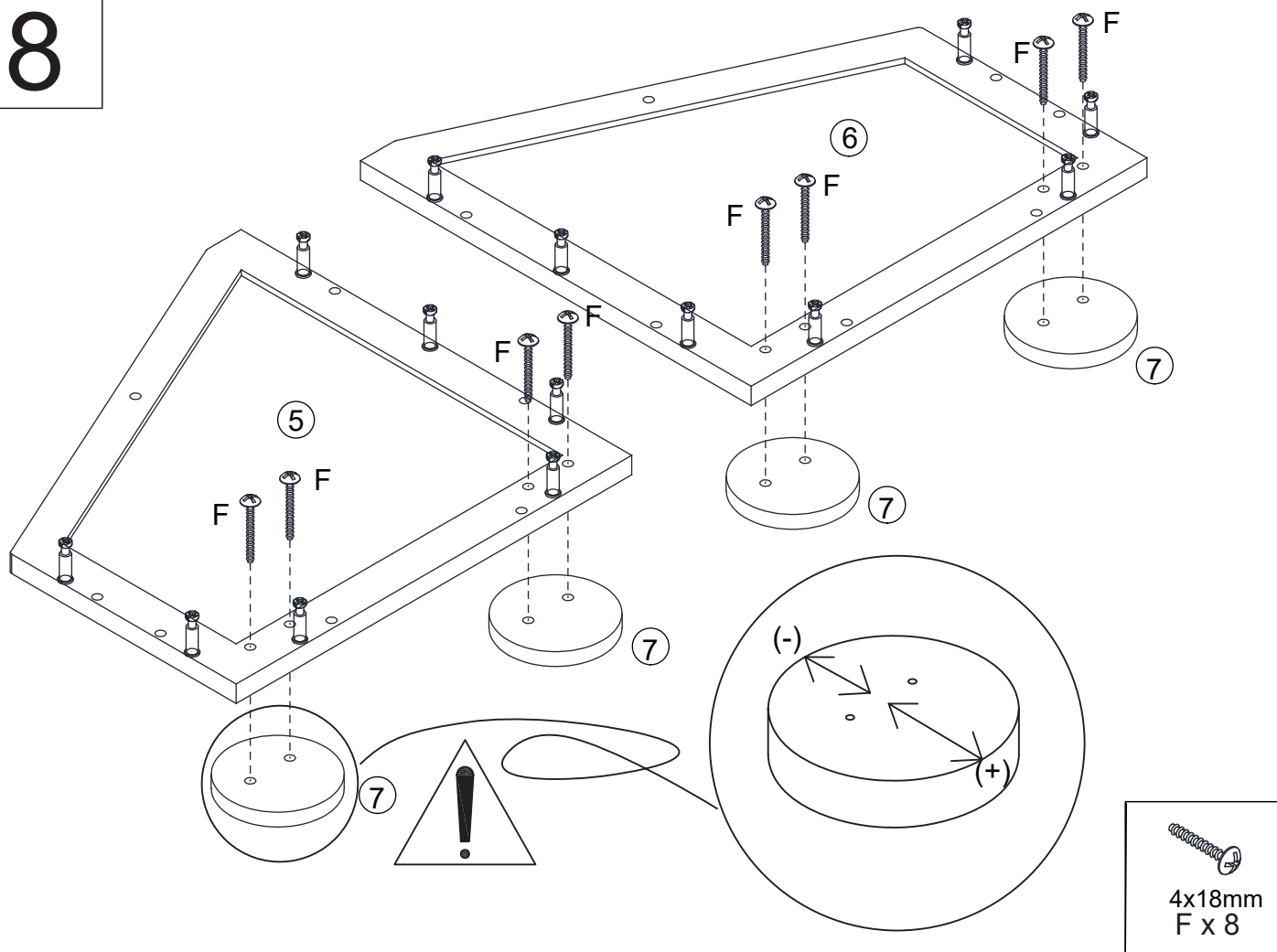

# 9

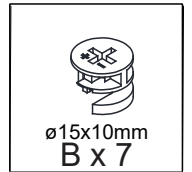
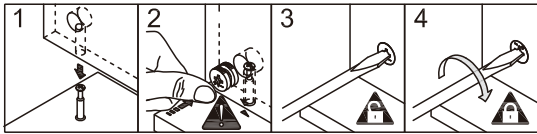
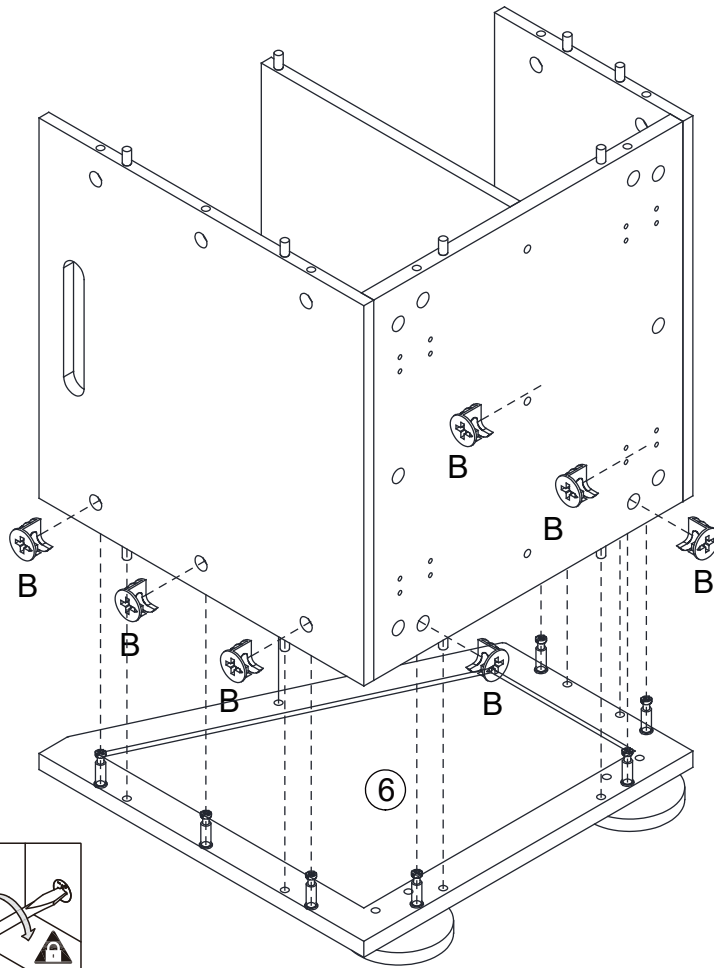

# 10

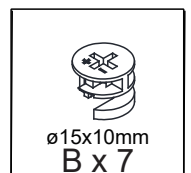
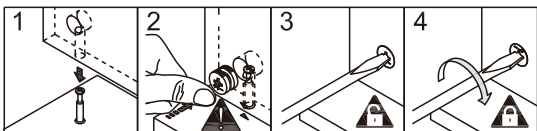
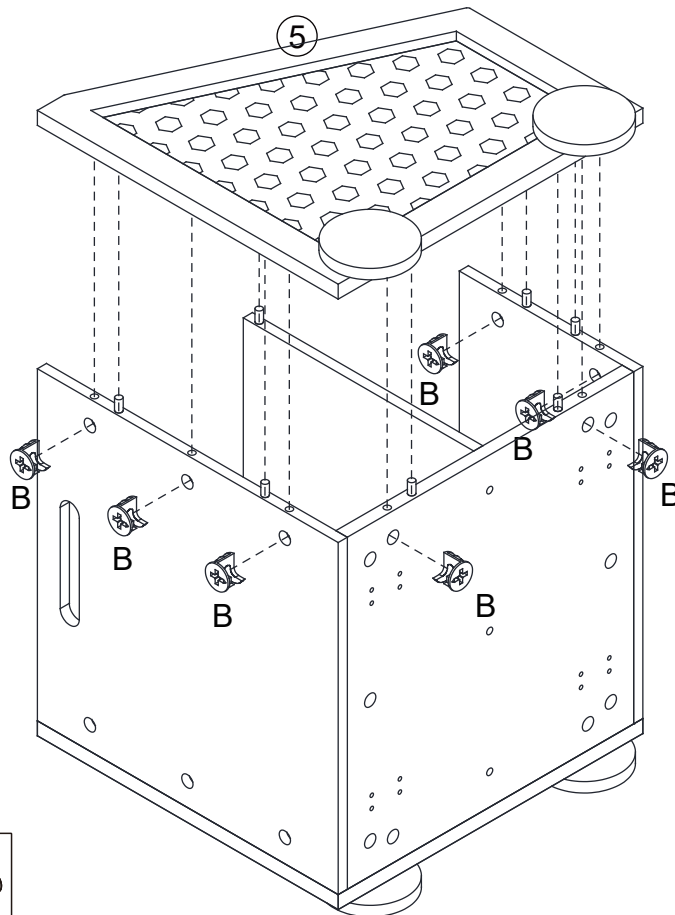

11

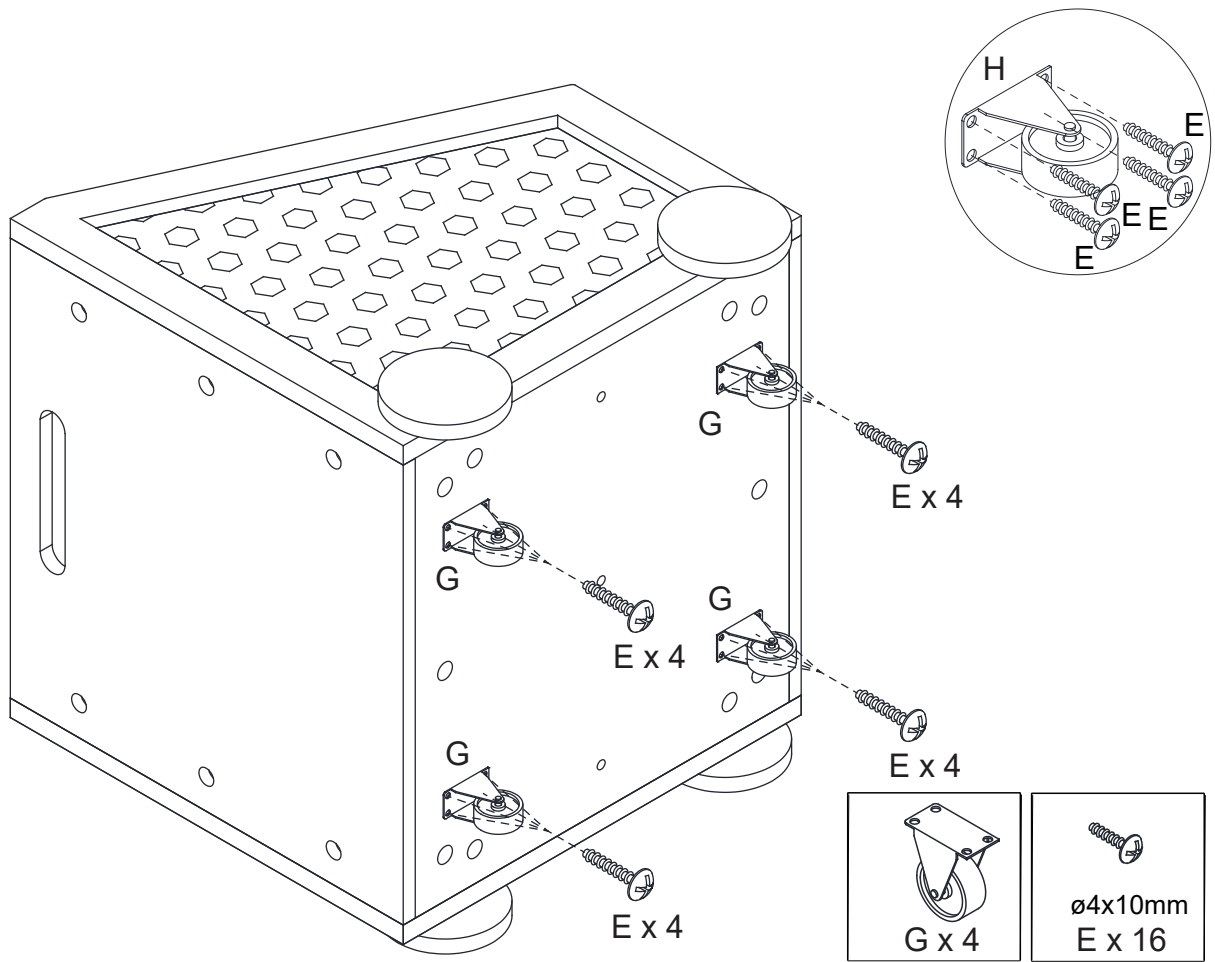

12

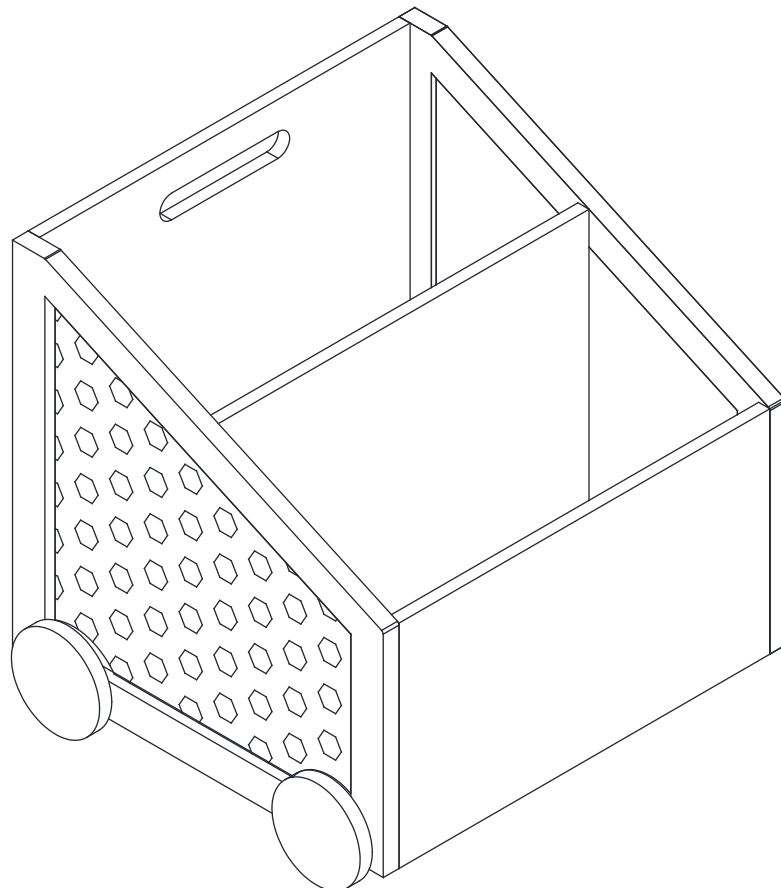

# 13

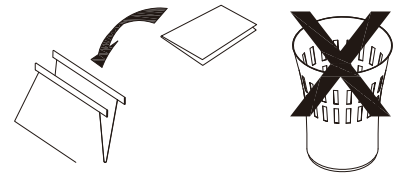
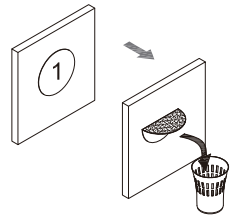
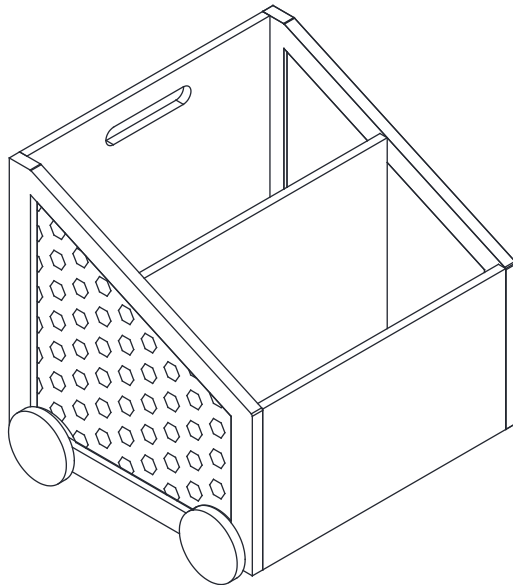

FR - Importé par / EN - Imported by / PT - Importado por / ES - Importado por  
/ DE - Importiert von / IT - Importato da / NL - Geïmporteerd door :  
UE/EU : Vertbaudet SAS - 36 avenue Alfred Lefrançois, 59200 Tourcoing, France  
UK: Vertbaudet UK Limited - Elder House, St Georges Business Park, 207  
Brooklands Road, Weybridge, Surrey KT13 0TS

Fabriqué en Chine  
made in China  
fabricado na China  
fabricado en China  
Hergestellt in China  
Made in China  
Geproduceerd in China